

**NSL** NSL Technology Resources (s) Pte Ltd  
No 280 Woodlands Industrial Park E5,  
#09-11 Harvest @ Woodlands,  
Singapore 757322  
Tel : +65 67957477, 7747 Fax : +65 63162368  
Email : sales@nsstechnology.com



SUPPLYING PRESSURE TO INDUSTRY



**Pressure Sustaining**  
**Power on Demand**  
**ATEX Approval Ex II 2 G D,c T6**  
**Infinitely Variable Flow**  
**Energy Efficient**  
**Fluid Pressures from 5 to 680 bar**  
**Quality Engineered**  
**Worldwide Availability**

**KR & GX PUMPS**

Air Driven Pumps and Power Packs

**HEYPAC** is a world leader in the development, manufacture and marketing of a range of the most advanced air driven fluid pumps and hydraulic power units.

The company was established in 1978 and since then has developed a unique product line of hydraulic equipment to satisfy industrial requirements for "power on demand".

The rugged design and build quality of the range can provide a cost effective and energy efficient product for use with a variety of fluids in many industrial, mobile and marine applications.

The GX and KR series includes a wide range of flow and pressure options and can be supplied in either basic pump form, complete with an integral reservoir or as a fully assembled power unit.

The wide range of complimentary accessories ensures that the GX and KR series pumps can be tailored to fit a wide range of applications in the most demanding conditions.

**HEYPAC** air driven fluid pumps and hydraulic power units are designed and manufactured in the United Kingdom, under a quality management system approved by Lloyd's Register Quality Assurance to ISO9001:2000.

**HEYPAC** products have been sold throughout the world through our own associate companies and authorized distributors, who operate in Europe, North America, Africa, the Middle and Far East and Australia. All associate companies and distributors have been fully trained and are able to offer application advice, local product availability, after sales support and service facilities. Further details are available on request or from the web site

The technical information contained in this catalogue, which does not purport to be comprehensive, has been provided by **HEYPAC** Limited as a general guide and should not be used as an alternative to obtaining individual technical advice specific to the intended application. While this information has been prepared in good faith, no representation or warranty, express or implied, is or will be made and no responsibility or liability is or will be accepted by **HEYPAC** Limited or by any of their respective officers, employees or agents in relation to the accuracy or completeness of the technical information contained in this catalogue and any such liability is expressly disclaimed.



## Contents

Principal Operation	Page 3
GX Range	Page 4
KR Range	Page 6
Sizes and Specifications	Page 8
Installation Considerations	Page 9
Accessories	Page 10
Ordering Codes	Page 16

The **HEYPAC** is a **double acting**, free piston, compressed air driven hydraulic pump of **infinitely variable** delivery for general use wherever a compressed air supply is available. The pump will **cycle automatically** according to system demand and stall under **zero flow** conditions with **minimal energy consumption**. The output flow and pressure depend upon the intensification ratio relative to the air supply pressure and volume.

The air operated fluid pumps and hydraulic power packs are currently available with fluid-to-air pressure ratios from 2.5:1 to 80:1. All models employ similar air drives with only the fluid end varying in size to produce the different pressure intensification ratios. Key areas of the pumps construction and operation are described below.

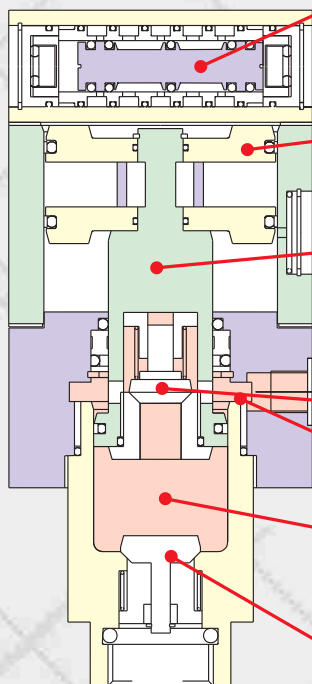

**AIR VALVE** - a self reciprocating valve that alternates the compressed air supply to the upper and lower sides of the drive piston assembly generating the pumping motion of the unit. A unique system of pilot control produces positive spool reversal.

**AIR DRIVE** - a lightweight drive piston complete with self lubricating seals allows the pump to operate on an unlubricated air supply.

**PISTON ROD** - transmits the compressed air power to the fluid being pumped. The cross sectional area of this piston in relation to the air drive piston provides the pump intensification ratio.

**TRANSFER VALVE** - is closed as the piston rises, drawing fluid into the lower pump chamber **B** via the suction valve and at the same time the piston displaces fluid from the upper chamber **A** to the system. When the pump reverses and the piston rod begins to fall the suction valve is closed by the increase in pressure in the lower chamber and the transfer valve is opened. Fluid is then displaced through the transfer valve to the upper chamber where the excess fluid is again forced into the system.

**SUCTION VALVE** - opens to allow fluid to enter the pump as the piston assembly rises.

Model	GX025	GX05	GX10	GX20	GX30	GX40	GX60	GX80
Ratio fluid: air	2.5:1	5:1	10:1	20:1	30:1	40:1	60:1	80:1
P max-fluid bar (psi)	17.5 (254)	35 (508)	70 (1015)	140 (2030)	210 (3045)	280 (4060)	420 (6090)	560 (8120)
Q max fluid L/min (US gpm)	80 (21.1)	40 (10.6)	20 (5.3)	10 (2.6)	7.5 (1.98)	5.0 (1.3)	3.8 (1.0)	2.5 (0.66)
Q max ave fluid L/min (US gpm)	22 (5.8)	11 (2.9)	5.5 (1.45)	2.8 (0.74)	2.1 (0.55)	1.4 (0.37)	1.0 (0.26)	0.7 (0.18)

\* For definitions of Q Max and Q Max ave see 'Technical Data' section on page 7.

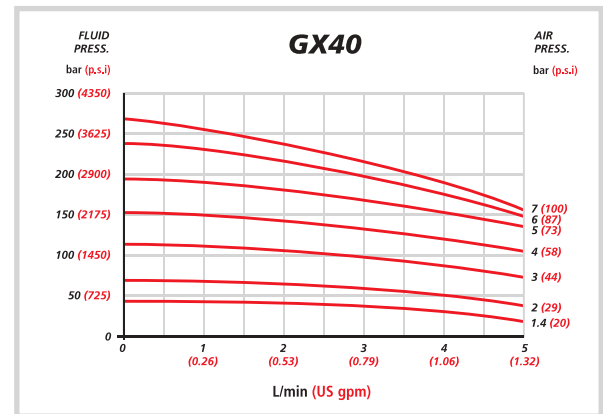
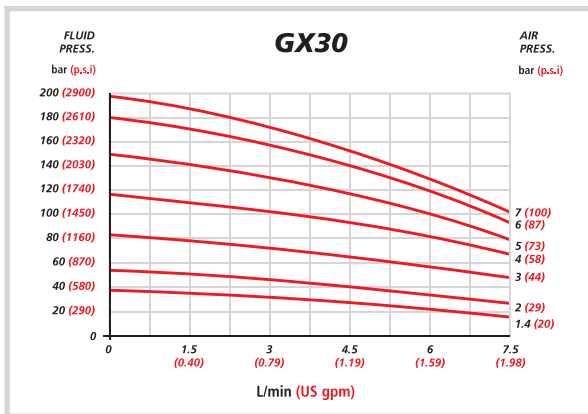
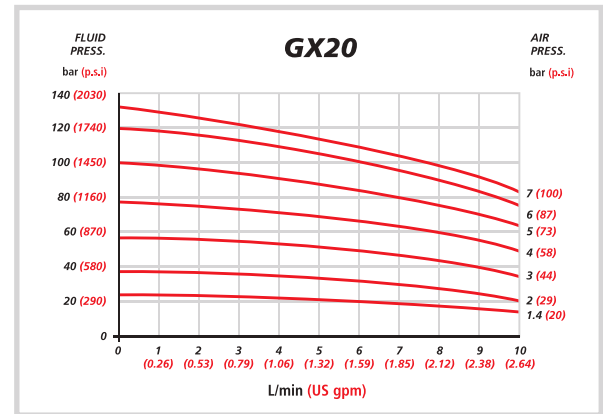
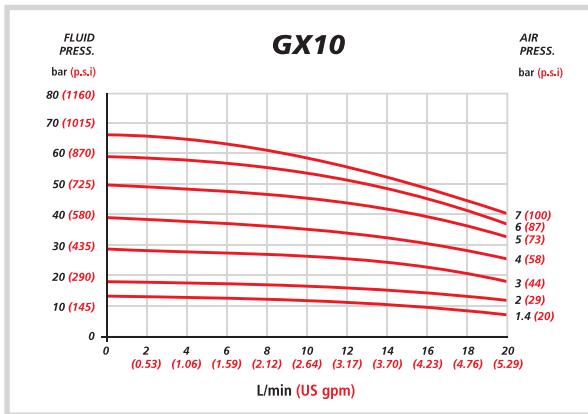
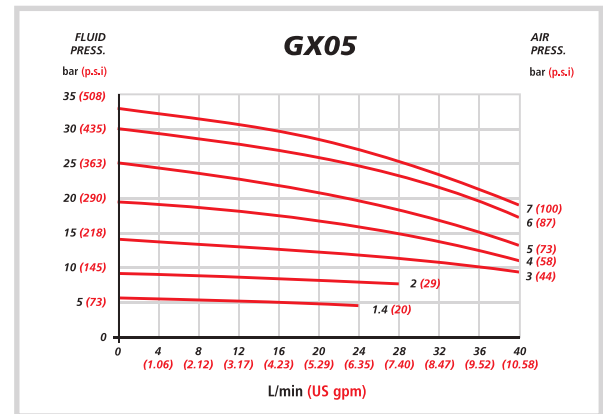
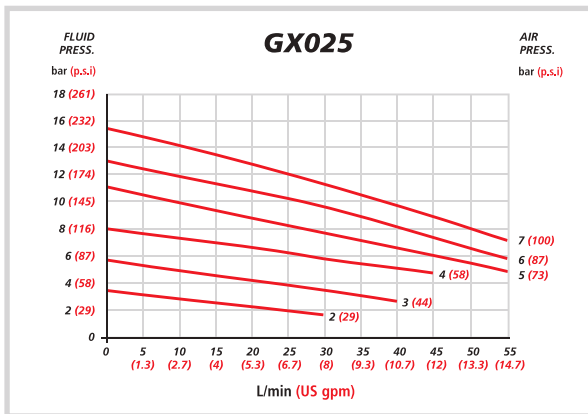

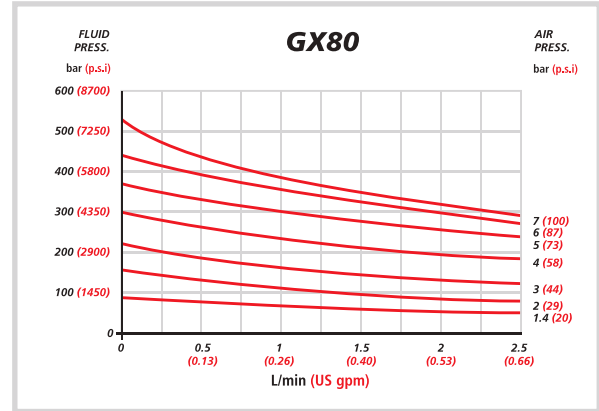
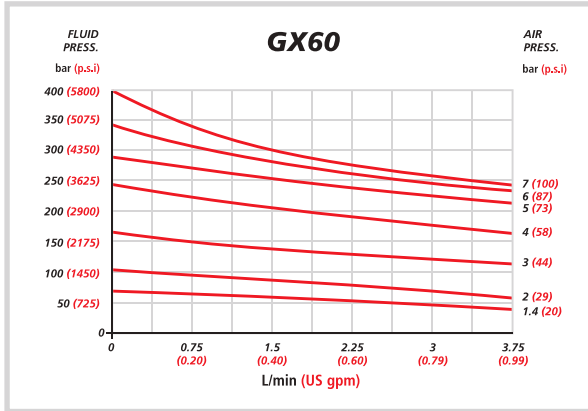

## Dimensions

Model	Dim'n 'A'	Dim'n 'B'
GX025	4 (0.2")	303 (11.9")
GX05	91 (3.6")	188 (7.4")
GX10	73 (2.9")	188 (7.4")
GX20<80	66 (2.6")	188 (7.4")

### Other Option Dimensions :-

'OO' - As T1 but without Flange
'W1' - As R2 but without Reservoir
'R1' - As R2 but Reservoir Ø 152 (6")
'R3' - As R1 but for horizontal mounting
'R4' - As R2 but for horizontal mounting

### Type 'R2'

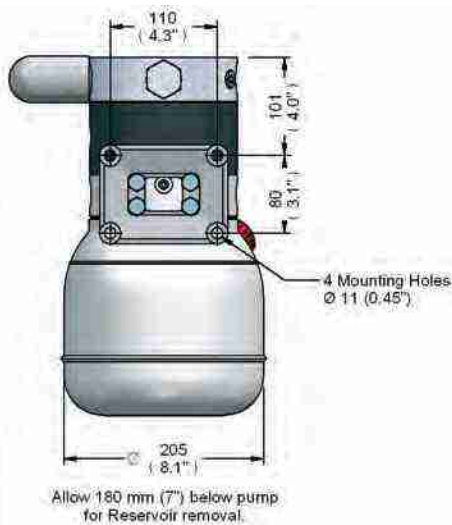
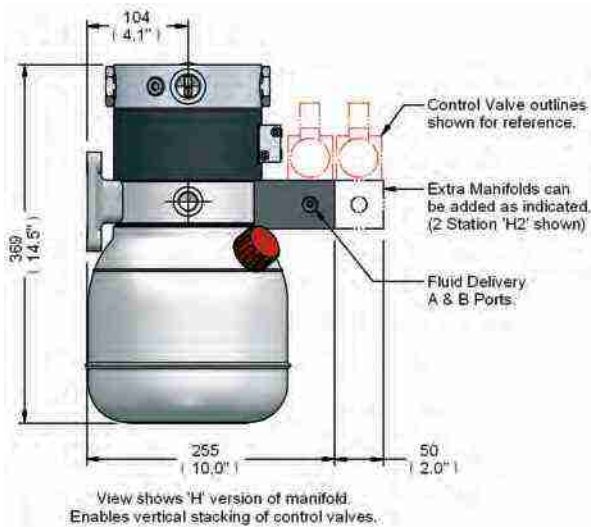

### Type 'T1'

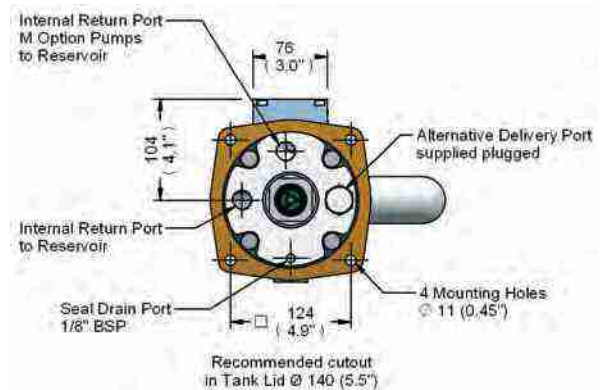
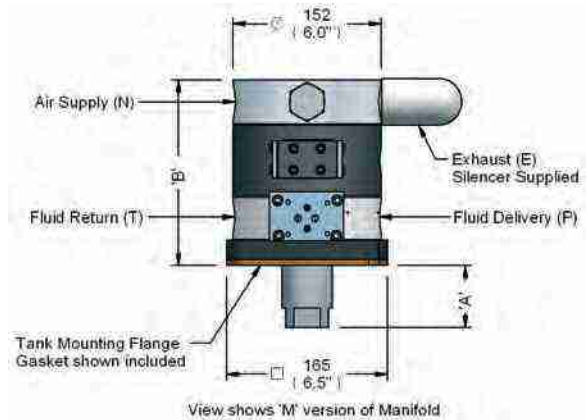

# Performance

Model	KR02	KR05	KR10	KR20	KR40	KR80
Ratio fluid: air	2:1	5:1	10:1	20:1	40:1	80:1
P max-fluid bar (psi)	13.5 (200)	42.5 (615)	85 (1230)	170 (2460)	340 (4920)	680 (9840)
Q max fluid l.min (US gpm)	15 (4)	10 (2.65)	5 (1.32)	2.5 (0.65)	1.2 (0.32)	0.5 (0.13)
Q max ave fluid l.min (US gpm)	4 (1)	2.8 (0.74)	1.4 (0.37)	0.7 (0.18)	0.35 (0.09)	0.17 (0.04)



\* For definitions of Q Max and Q Max ave see 'Technical Data' section on page 7.

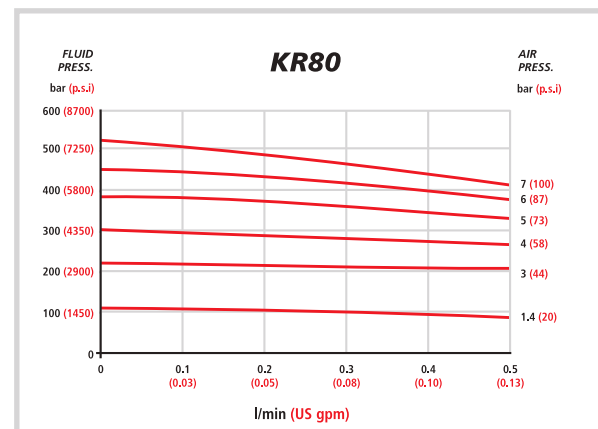
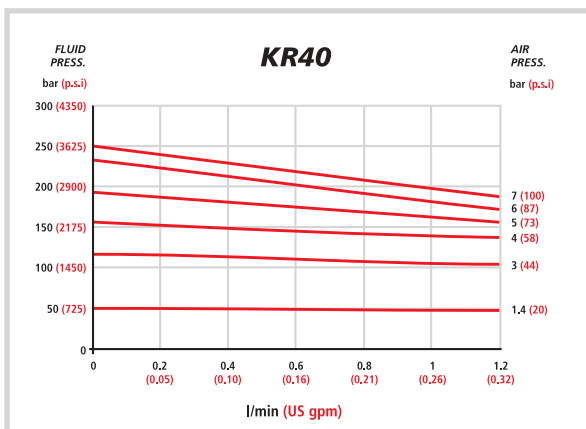
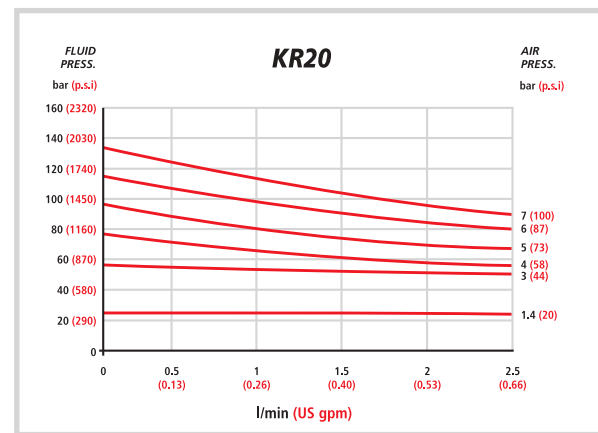
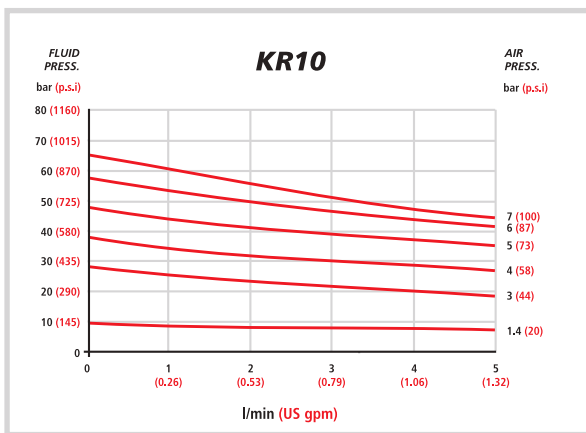
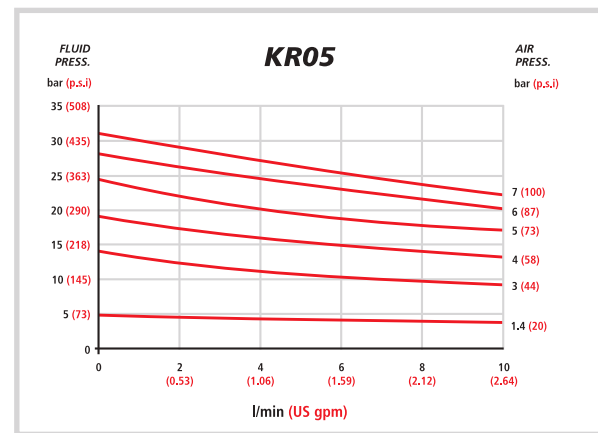
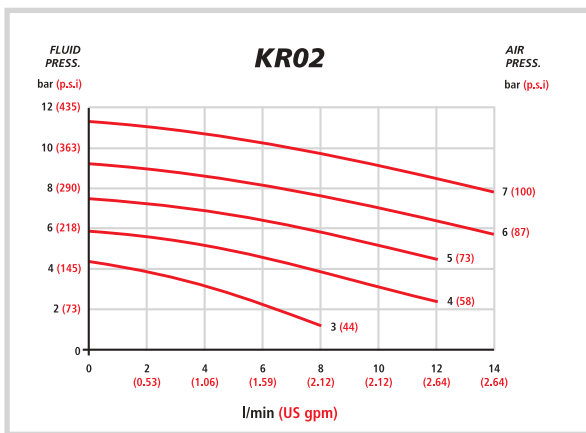

## Dimensions

### Type R5

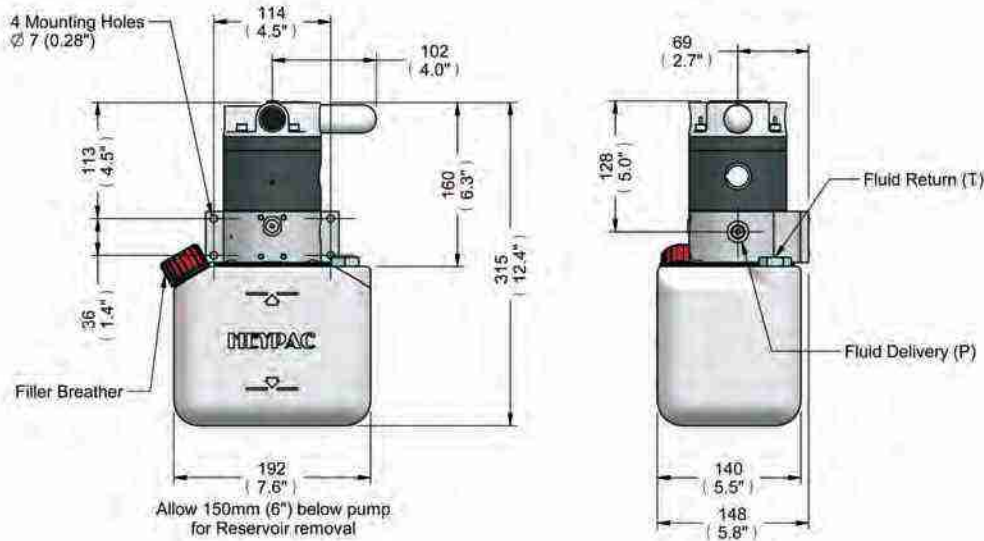

Model	Dim'n 'A'	Dim'n 'B'
KR02	11 (0.4")	213 (8.4")
KR05 & 10	50 (2.0")	168 (6.6")
KR20 & 40	35 (1.4")	168 (6.6")
KR80	26 (1.0")	168 (6.6")

#### Other Option Dimensions :-

'OO' - As T2 but without Flange
'R5M' - As R5 but with Manifold
'W2' - As R5 but without reservoir

### Type T2

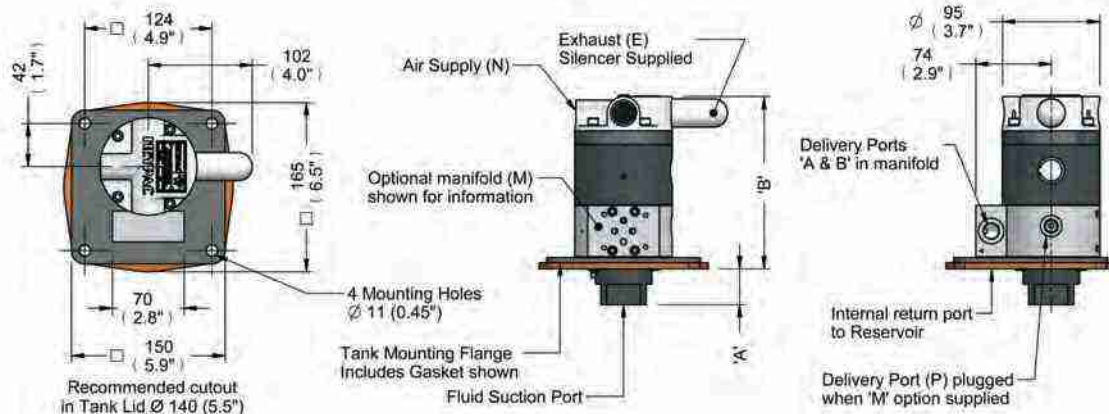

## Technical Data

#### Air consumption

For details on air consumption please contact **HEYPAC** or your local distributor.

#### Maximum hydraulic power

**GX series** - 1.5 kW (2.0 hp)  
**KR series** - 0.37kW (0.5 hp)

#### Maximum cycle speed

500 cycles/minute (intermittent).  
 For continuous duty maximum cycle speed should be reduced to approx. 50 - 60 cycles/minute.  
 Applications involving continuous pumping should be referred to **HEYPAC**.

#### Maximum air pressure

**GX series** - 7.0 bar (100 psi)    **KR series** - 8.5 bar (125 psi)

#### Minimum air pressure

**GX and KR series** - 1.4 bar (20 psi)

#### Fluid temperature range

Minus 5 deg C to plus 70 deg C

#### "Q max."

Is defined as the maximum pump flow at 500 cycles/minute - intermittent duty only.

#### "Q max. avg"

Is defined as the maximum average allowable flow over the complete system operating cycle including both periods of pressure holding (stall condition) and fluid delivery.

## GX Range

Model: OO, T1, W1	Fluid Suction		Fluid Outlet		Fluid Outlet M Option		Alternative Outlet		Air Inlet	
	BSP	SAE	BSP	SAE	BSP	SAE	BSP	SAE	BSP	SAE
GX025	2" NPT	2" NPT	G 1"	1" NPT	N/A	N/A	N/A	N/A	G 3/4"	3/4" NPT
GX05	G 2"	2" NPT	G 3/4"	12 SAE	N/A	N/A	N/A	N/A	G 3/4"	3/4" NPT
GX10	G 1 1/2"	1 1/2" NPT	G 3/4"	12 SAE	G 3/8"	6 SAE	G 1/2"	8 SAE	G 3/4"	3/4" NPT
GX20/30/40	G 1"	16 SAE	G 1/2"	8 SAE	G 3/8"	6 SAE	G 1/2"	8 SAE	G 3/4"	3/4" NPT
GX60/80	G 1"	16 SAE	G 3/8"	6 SAE	G 1/4"	4 SAE	G 3/8"	6 SAE	G 3/4"	3/4" NPT
<b>Model: R1, R2, R4</b>							<b>Fluid Return</b>			
							<b>BSP</b>	<b>SAE</b>		
GX05	N/A	N/A	G 3/4"	12 SAE	N/A	N/A	G 3/4"	12 SAE	G 3/4"	3/4" NPT
GX10	N/A	N/A	G 3/4"	12 SAE	N/A	N/A	G 3/4"	12 SAE	G 3/4"	3/4" NPT
GX20/30/40	N/A	N/A	G 1/2"	8 SAE	G 3/8"	6 SAE	G 1/2"	8 SAE	G 3/4"	3/4" NPT
GX60/80	N/A	N/A	G 3/8"	6 SAE	G 1/4"	4 SAE	G 3/8"	6 SAE	G 3/4"	3/4" NPT

## KR Range

Model: OO, R5, T2, W2	Fluid Suction		Fluid Outlet		Fluid Outlet M Option		Fluid Return R5 Only		Air Inlet	
	BSP	SAE	BSP	SAE	BSP	SAE	BSP	SAE	BSP	SAE
KR02	G 1"	16 SAE	G 3/8"	6 SAE	N/A	N/A	G 3/8"	6 SAE	G 3/8"	3/8" NPT
KR05	G 1"	16 SAE	G 3/8"	6 SAE	G 3/8"	6 SAE	G 3/8"	6 SAE	G 3/8"	3/8" NPT
KR10	G 1"	16 SAE	G 3/8"	6 SAE	G 3/8"	6 SAE	G 3/8"	6 SAE	G 3/8"	3/8" NPT
KR20	G 1"	16 SAE	G 1/4"	4 SAE	G 3/8"	6 SAE	G 3/8"	6 SAE	G 3/8"	3/8" NPT
KR40	G 1"	16 SAE	G 1/4"	4 SAE	G 3/8"	6 SAE	G 3/8"	6 SAE	G 3/8"	3/8" NPT
KR80	G 1"	16 SAE	G 1/4"	4 SAE	N/A	N/A	G 3/8"	6 SAE	G 3/8"	3/8" NPT

### SAE Thread Designation

SAE	Thread
16 SAE	1 5/16" - 12UN-2B
12 SAE	1 1/16" - 12UN-2B
8 SAE	3/4" - 16UNF-2B
6 SAE	9/16" - 18UNF-2B
4 SAE	7/16" - 20UNF-2B



The **HEYPAC GX and KR series pumps** are rugged and high quality products and their long service life can be increased by correct installation.

## Filtration

Suction strainers (125 or 40 micron depending on model) are supplied in all units fitted with a reservoir but not included with 00, T and W configuration pumps.

Additional system filtration to 25 micron or better is recommended. An extended suction tube kit, complete with suction strainer, can be supplied for T configuration pumps that are to be tank mounted.

Air supply - an **auto drain** filter/regulator (25 micron) – see page 13 for details – should be fitted as close as possible to the air inlet and be of sufficient size for the air consumption anticipated. The air drives of the pumps are greased on assembly and therefore should not be used on lubricated air supplies as this will wash out the grease and shorten service life.



## Fluids

The pumps will handle a wide range of fluids, including those with little or no lubricating properties, but we do recommend that seal and fluid compatibility is checked prior to specifying a pump.

Fluids which have been satisfactorily pumped include:

- Mineral Oils**
- Vegetable Oils**
- High water-based fluids**
- Water Glycol solutions**
- Water in Oil emulsions**
- Phosphate Esters**
- Silicate Esters**
- Grease**
- Liquified Gases**

**Water** (For applications involving water, the option W should be inserted in the pump model number).

## Valves and System Components

Due to the pumps' ability to maintain pressure at zero flow, we recommend the fitting of ultra-low or no leakage valves, such as poppet construction types, to protect the pump from excessive cycling and premature wear. A range of suitable valves are available, please see pages 14 & 15.

## Mounting Orientation

Pumps can be mounted in any orientation with the exception of all R configuration pumps. The R1, R2 and R5 models must be mounted vertically with the reservoir beneath the pump while the R3 and R4 models should be mounted horizontally.

## Flow Control

A suitable flow control must be used if the pump is to be operated at or near maximum flow rate to prevent overspeeding.



## Smoothing Kits

to suit GX05, GX10 and GX20 pumps without valve manifolds

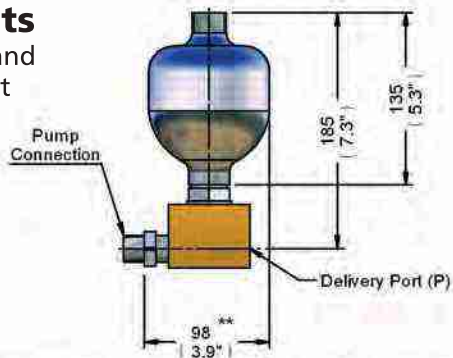

\*\* This dimension = 87mm (3.4") for GX20 Smoothing Kit. (HA20-N-01)

**HEYPAC** pumps are double acting single piston pumps and, as a result, produce small pressure pulsations. These can be significantly reduced by the addition of the appropriate smoothing kit to the outlet port of the pump. For maximum pulsation dampening the accumulator should be installed as close to the outlet port as possible.

- Maximum operating pressure 170 Bar.
- Fluid Type – Mineral Based Hydraulic Oils.

### ORDERING CODES

#### Pump ratio Codes

5:1	HA05-BN-01 (BSP Ported) or HA05-SN-01 (SAE Ported)
10:1	HA10-BN-01 (BSP Ported) or HA10-SN-01 (SAE Ported)
20:1	HA20-BN-01 (BSP Ported) or HA20-SN-01 (SAE Ported)

## Smoothing Kits

to suit GX30, GX40 and GX60 series pumps without valve manifolds

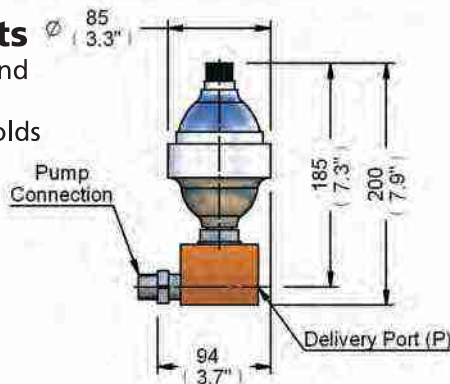

**HEYPAC** pumps are double acting single piston pumps and, as a result, produce small pressure pulsations. These can be significantly reduced by the addition of the appropriate smoothing kit to the outlet port of the pump. For maximum pulsation dampening the accumulator should be installed as close to the outlet port as possible.

- Maximum operating pressure 500 Bar.
- Fluid Type – Mineral Based Hydraulic Oils.

### ORDERING CODES

#### Pump ratio Codes

30:1	HA30-BN-01 (BSP Ported) or HA30-SN-01 (SAE Ported)
40:1	HA40-BN-01 (BSP Ported) or HA40-SN-01 (SAE Ported)
60:1	HA60-BN-01 (BSP Ported) or HA60-SN-01 (SAE Ported)

## Smoothing Kits

to suit GX20 pumps with manifolds



**HEYPAC** pumps are double acting single piston pumps and, as a result, produce small pressure pulsations. These can be significantly reduced by the addition of the appropriate smoothing kit to the outlet port of the pump. For maximum pulsation dampening the accumulator should be installed as close to the outlet port as possible.

- Maximum operating pressure 170 Bar.
- Fluid Type – Mineral Based Hydraulic Oils.

### ORDERING CODES

#### Pump ratio Codes

20:1	HA20-BN-01M (BSP Ported) or HA20-SN-01M (SAE Ported)
------	---

## Smoothing Kits

to suit GX30, GX40 and GX60 pumps with manifolds

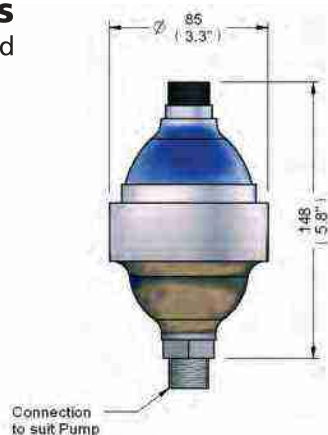

**HEYPAC** pumps are double acting single piston pumps and, as a result, produce small pressure pulsations. These can be significantly reduced by the addition of the appropriate smoothing kit to the outlet port of the pump. For maximum pulsation dampening the accumulator should be installed as close to the outlet port as possible.

- Maximum operating pressure 420 Bar.
- Fluid Type – Mineral Based Hydraulic Oils.

### ORDERING CODES

#### Pump ratio Codes

30:1	HA30-BN-01M (BSP Ported) or HA30-SN-01M (SAE Ported)
40:1	HA40-BN-01M (BSP Ported) or HA40-SN-01M (SAE Ported)
60:1	HA60-BN-01M (BSP Ported) or HA60-SN-01M (SAE Ported)

## GX Return Line Filters

to suit GX05 to GX 80 series pumps without valve manifold

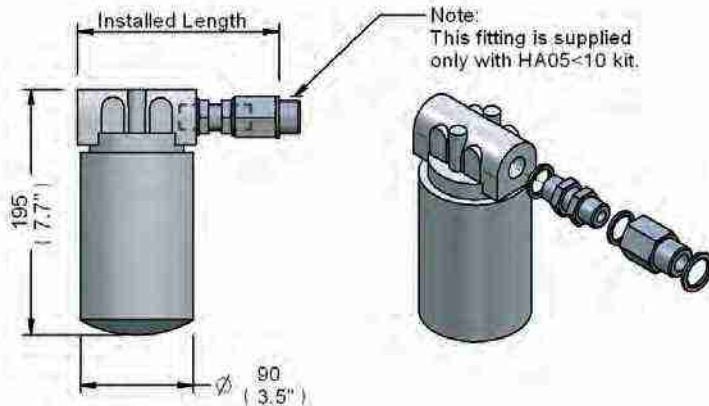

A range of line mounted 10 micron return filters to suit GX05 to GX80 series pumps. The filter is available as a stand-alone item or in a kit, which also contains all necessary fittings to mount the filter to the pump return port.

- Maximum working pressure 14 Bar.
- Maximum flow rate 90 lpm.
- Fluids - Petroleum Based Only
- Not suitable for GX pumps with valve manifold

### ORDERING CODES

Description	Part Number	To Suit Pump Types	Fittings Incl.
Basic Filter	HA-GRLF-10	GX05 to GX80	No
Filter Kit	HA05<10-GRLF-10	GX05 and GX10	Yes
Filter Kit	HA20<40-GRLF-10	GX20, GX30 and GX40	Yes
Filter Kit	HA60<80-GRLF-10	GX60 and GX80	Yes

Replacement Element Part No. HSE-3000

## Return Line Filter

to suit GX20, 30 and 40 series pump with valve manifold

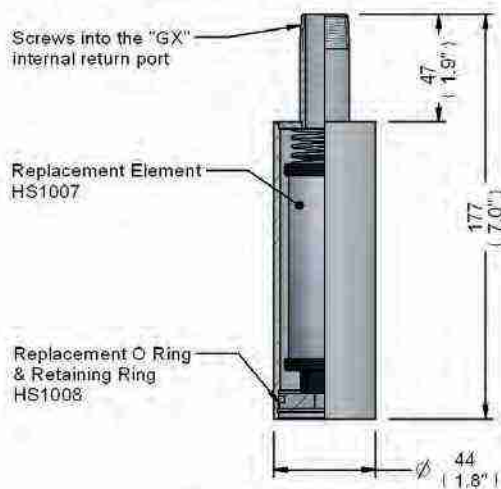

A return line filter, especially suitable for use with manifold equipped GX20, GX30 and GX40 series pumps. The filter screws into the return port (G1/2" BSPT) on the bottom face of the pump flange. It is only suitable for use with R1, R2 and 10 litre capacity reservoirs.

- Filtration level: 20 micron (nominal)
- Filter material: Paper (Wire supported)
- Fluid compatibility: Mineral & lubricating oils only
- Temperature range -10 to + 100deg. C
- Pressure drop: 0.06 bar at 30 lpm

### ORDERING CODES

Description	Code:
Return Filter Assembly	HA20/40-XXN-09
Filter element	HS1007
Spares Kit	HS1008

## KR Return Line Filters

to suit KR05 to KR80 series pump without valve manifold

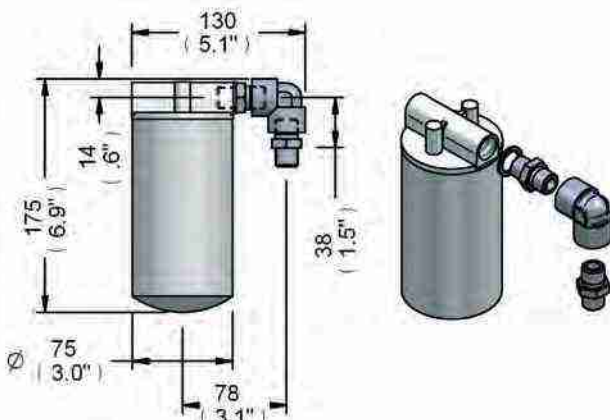

A range of line mounted 10 micron return filters to suit KR05 to KR80 series pumps. The filter is available as a stand-alone item or in a kit, which also contains all necessary fittings to mount the filter to the pump return port.

- Maximum working pressure 14 Bar.
- Maximum flow rate 31 lpm.
- Fluids - Petroleum Based Only
- Not suitable for KR pumps with valve manifold

### ORDERING CODES

Description	Part Number	To Suit Pump Types	Fittings Incl.
Basic Filter	HA-KRLF-10	KR05 to KR80	No
Filter Kit	HA05<80-KRLF-10	KR05 to KR80	Yes

Replacement Element Part No. - HSE 3001

## 10 Litre Reservoir Kit

The 10 litre reservoir kit contains all components necessary to form a self contained power pack with one GX or KR series pump. The reservoir assembly, manufactured of steel and finished in a black epoxy powder coating, includes tank, tank lid complete with filler breather and mounting position for one pump, fluid level gauge and drain port. An extended pump suction and return tube is also provided.

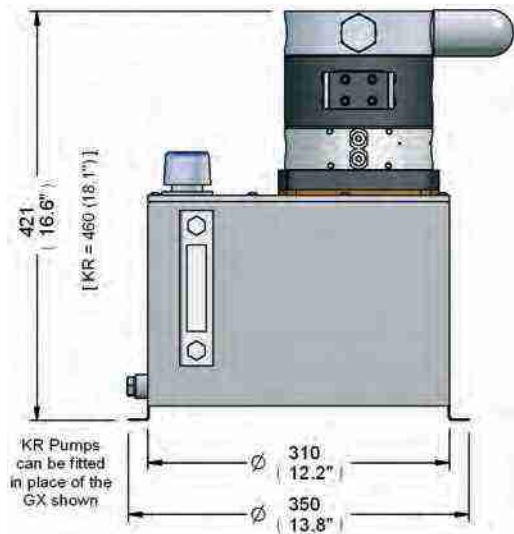

### ORDERING CODES

Description	Code:
Basic part no.	HA**-BN-10
** - insert pump size to be fitted as follows:	
GX05	05
GX10	10
GX20, GX30, GX40, GX60 or GX80	20<80
All KR series pumps	20<80
No pump	XX

### Example:

Reservoir kit for GX40 pump - part no. = HA20<80-BN-10

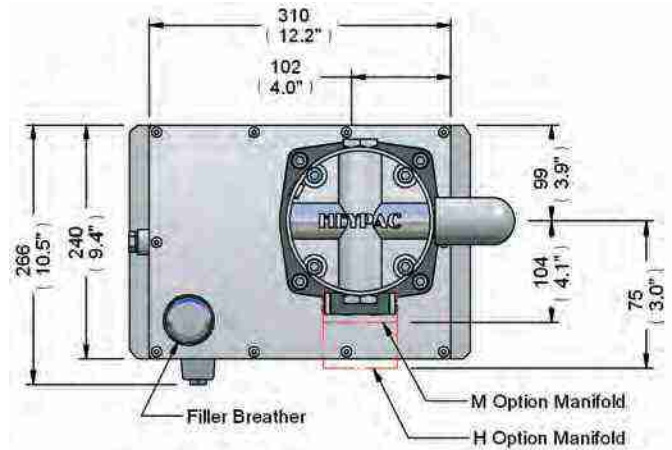

## 30 Litre Reservoir Kit

The 30 litre reservoir kit contains all components necessary to form a self contained power pack capable of employing one or two pumps. The reservoir assembly, manufactured of steel and finished in a black epoxy powder coating, includes tank, tank lid complete with filler breather, return line filter and mounting positions for two pumps, fluid level gauge and drain port. Extended pump suction and return tubes are supplied.

**Note:** The diagrams show 2 x GX pumps. KR pumps or one of each GX & KR or single pumps may be fitted, each pump can be orientated 4 by 90° to suit installation.

### ORDERING CODES

Description	Code:
Basic part no.	HA**/**-BN-30
** - insert pump size to be fitted as follows:	
GX025	025
GX05	05
GX10	10
GX20, GX30, GX40, GX60 or GX80	20<80
All KR series pumps	20<80
No pump	XX

### Example:

Reservoir kit for GX05 & GX40 pumps - part no. = HA05/20<80-BN-30

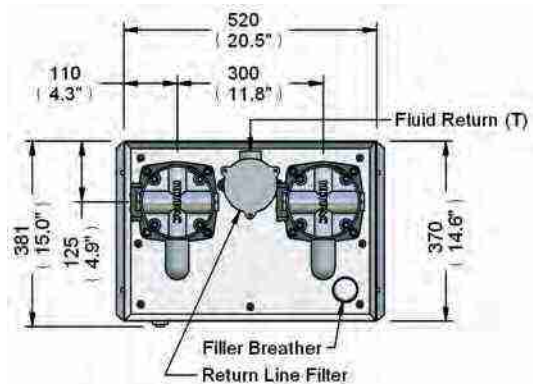
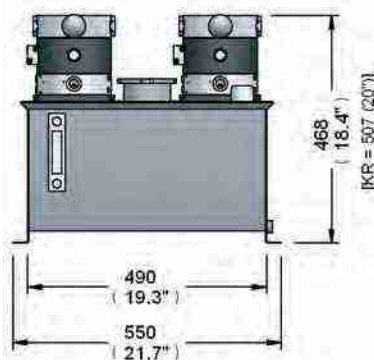

## Level switches

Level switches include DIN type electrical connector. The float cannot be damaged by puncturing and is compatible with hydrocarbon based fluids and lubricants. The standard switch is normally open at high fluid levels and closes as level drops. Reverse switching is available – please contact us.

- Maximum switching voltage – 300VDC/240VAC

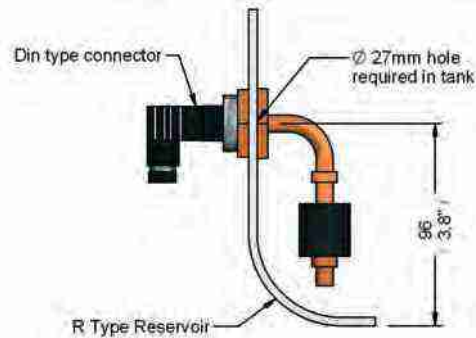

## ORDERING CODES

### Description

To fit R1, R2 and R5 type reservoir bowls  
To fit 10 litre reservoir assembly  
To fit 30 litre reservoir assembly

### Codes

HAXX-XXN-02R  
HAXX-XXN-02T10  
HAXX-XXN-02T30

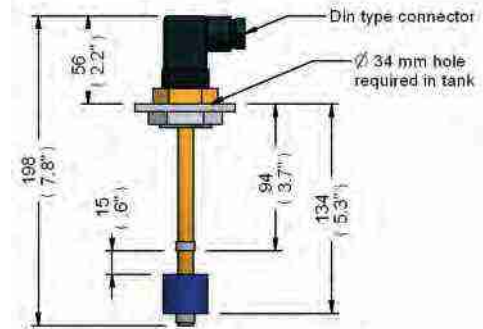

Note: Dimensions shown are for the T10  
Stem length for T30 is 50mm longer

## Air Filter/Regulator Assembly



A range of compressed air filter regulators with automatic drain, pressure gauge and fitting to enable direct mounting on GX and KR series pumps. Additional wall mounting brackets, shut-off valves and emergency dump valves are available upon request.

**Note:** To achieve maximum flow and pressure with GX series pumps use 6B\* or 6N\* variant of filter/regulator..

## ORDERING CODES

Pump range	thread	Codes
GX**-B**	G 1/2"	HA-FR-GX-4B
GX**-B**	G 3/4"	HA-FR-GX-6B*
GX**-S**	1/2" NPT	HA-FR-GX-4N (US use only)
GX**-S**	3/4" NPT	HA-FR-GX-6N* (US use only)
KR**-B**	G 3/8"	HA-FR-KR-3B
KR**-S**	1/4" NPT	HA-FR-KR-2N (US use only)

## Pressure Reducing Valve

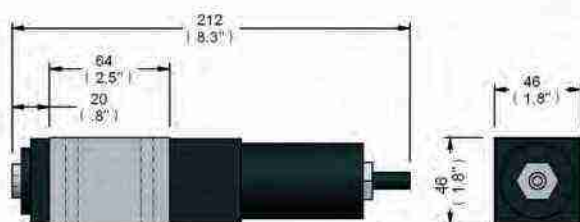
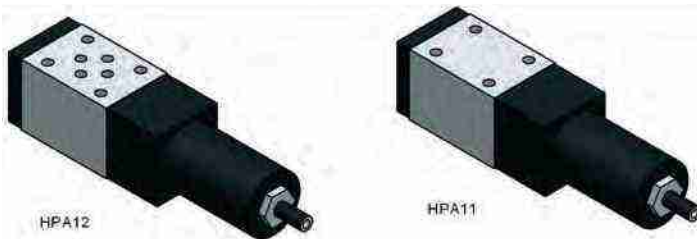

A direct operated CETOP03/DO3/NG6 pressure reducing valve for use with **HEYPAC** pumps. The valve is supplied in either "flange" form (HPA11) for use as a single sub-plate mounted valve or "sandwich" form (HPA12) for use as part of a valve stack. The reduced pressure is adjustable by means of a socket head screw.

- Maximum Inlet Pressure 315 Bar.
- Maximum Flow rate 20l/min.
- Reduced Pressure Ranges – See ordering code

## ORDERING CODES

### Description

Main code

### Model:

Flange Mount  
Sandwich Mount

### Reduced Pressure Port:

"A" port (HPA 11 & HPA 12)  
"B" port (HPA 12 only)  
"P" port (HPA 12 only)

### Adjuster:

Socket head screw

### Reduced Pressure Range:

5 - 315 Bar  
5 - 200 BAR  
4 - 160 BAR  
4 - 125 BAR  
2 - 63 BAR  
1 - 31.5 BAR

### Codes

**HPA 11 - A X - 200**

HPA 11  
HPA 12

A  
B  
P

X

315  
200  
160  
125  
63  
31

## W2 Poppet Directional Valves

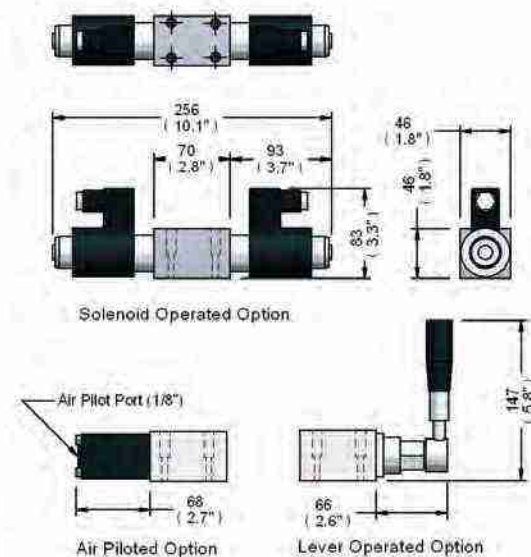

W2 Series ultra low leakage Poppet Directional Valves – CETOP03/DO3/NG6 manifold interface.

- Available in 2/2, 3/2, 3/3, 4/3 and 4/4 configurations.
- Solenoid, air pilot or lever operation in most types. Manual override as standard on solenoid operated versions.
- Available with or without check valve or orifice disc in pressure port.
- Special versions for accumulator and clamping systems with closed-crossover switching characteristics. Maximum flow rate 10l/min. Standard version W2N becomes W2P.
- Coils can be replaced without disturbing or opening the hydraulic system.
- Maximum pressure W2 series 315bar NBVP series 400bar.
- Maximum flow 20 l/min (W2N types) or 10l/min (W2P types).
- Fluid Temp. Range: -20 deg. C. +70 deg. C
- Preferred voltages: 24V DC, 115V AC50-60Hz or 230V AC50-60Hz – others available on request.
- Minimum pilot pressure of 5 bar is recommended for air operated valves.
- Mounting attitude: Unrestricted

Valve Symbol	Model No. Function	Ordering Code
	<b>W2*-****-6**</b> <b>2 Port 2 Position</b>	Solenoid Operated, Air Operated and Lever Operated. Contact <b>HEYPAC</b> or your distributor for ordering codes
	<b>W2*-****-6**</b> <b>2 Port 2 Position</b>	Solenoid Operated, Air Operated and Lever Operated. Contact <b>HEYPAC</b> or your distributor for ordering codes
	<b>W2N-32ON-6AB</b> <b>3 Port 2 Position</b>	Solenoid Operated W2N-32ON-6AB x Voltage/Hz Air Operated W2N-32ON-6RAD Lever Operated W2P-32ON-6VAB
	<b>W2N-32SN-6AB</b> <b>3 Port 2 Position</b>	Solenoid Operated W2N-32SN-6AB x Voltage/Hz Air Operated W2N-32SN-6RAD Lever Operated W2P-32SN-6VAB
	<b>W2N-33RN-6AB</b> <b>3 Port 3 Position</b>	Solenoid Operated W2N-33RN-6AB x Voltage/Hz Air Operated W2N-33RN-6QAD Lever Operated W2P-33RN-6VAB
	<b>W2N-43FN-6AB</b> <b>4 Port 3 Position</b>	Solenoid Operated W2N-43FN-6AB x Voltage/Hz Air Operated W2N-43FN-6RAD Lever Operated W2P-43FN-6VAB
	<b>W2N-43GN-6AB</b> <b>4 Port 3 Position</b>	Solenoid Operated W2N-43GN-6AB x Voltage/Hz Air Operated W2N-43GN-6RAD Lever Operated W2P-43GN-6VAB
	<b>NBVP-16G-WG</b> <b>4 Port 3 Position</b>	Solenoid Operated NBVP-16G-WG x Voltage/Hz

## Rotary Lever Operated Valves

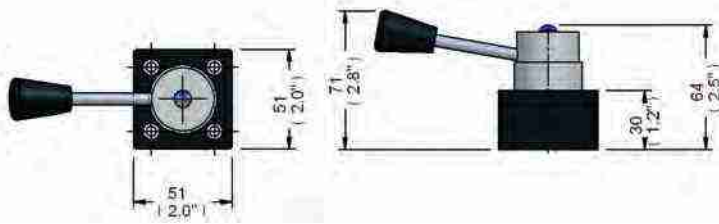

A range of ultra low leakage, manifold mounted rotary lever operated valves for pressures up to 414 Bar (6000psi) and maximum flow rate 12lpm. The valves have extremely low leakage, less than one drop per two minutes at rated pressure. They are compact, lightweight and shift easily even under maximum pressure. The manifold interface conforms to CETOP03/DO3/NG6. As well as the manifold connection, the valves are also available in body-ported versions to special order. The valves are constructed of heat-treated alloy steel and aluminium components. The valves are suitable for use with mineral based oils. For use with other fluids please contact **HEYPAC** or your local distributor.

### Valve Symbol

### Function

### Ordering Code

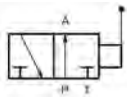

**3 Port 2 Position**

**MDCM-035-NO**

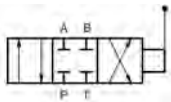

**4 Port 3 Position**

**MDCM-045-NO**

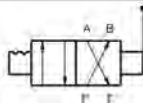

**4 Port 2 position  
Detented**

**MDCM-045-NO-D**

## Valve Manifold Block

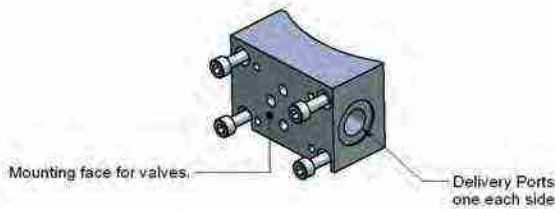

A range of manifold blocks that enable valves conforming to CETOP03/DO3/NG6 standard to be mounted directly on to pumps.

### ORDERING CODES

Pump Range	Codes	Thread
KR05 to KR40	KS05<40-BXV-64K	G 3/8"
KR05 to KR40	KS05<40-SXV-64K	6 SAE
GX10 to GX40	GS20<40-BXV-64K	G 3/8"
GX10 to GX40	GS20<40-SXV-64K	6 SAE
GX60 to GX80	GS60<80-BXV-64K	G 1/4"
GX60 to GX80	GS60<80-SXV-64K	4 SAE

## Valve Manifold Block

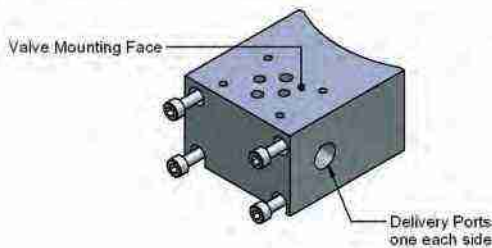

A range of manifold blocks that enable valves conforming to CETOP03/DO3/NG6 standard to be mounted directly on to pumps.

### ORDERING CODES

Pump Range	Codes	Thread
GX10 to GX40	GS20<40-BXV-64KH	G 3/8"
GX10 to GX40	GS20<40-SXV-64KH	6 SAE

## 2 Station Valve Manifold Block

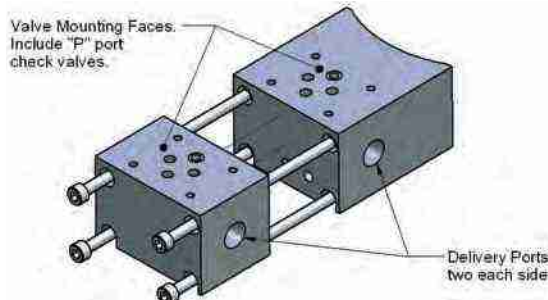

A range of manifold blocks that enables 2 valves conforming to CETOP03/DO3/NG6 standard to be mounted directly on to pumps.

Each manifold section is fitted with an integral pressure port check valve. It is possible to fit additional manifold sections - please consult **HEYPAC** for details.

### ORDERING CODES

Pump Range	Codes	Thread
GX10 to GX40	GS20<40-BXV-64KH2	G 3/8"
GX10 to GX40	GS20<40-SXV-64KH2	6 SAE

# Ordering Information

## GX PUMP RANGE

**E GX40- B P V- 00 M-W-DM\*\***

**E\*\* ATEX Approved** to Ex II 2 G D,c T6 (85) – Omit if standard pump required.

### Fluid/air pressure ratio:

**GX025** - 2.5:1    **GX05** - 5:1    **GX10** - 10:1  
**GX20** - 20:1    **GX30** - 30:1    **GX40** - 40:1  
**GX60** - 60:1    **GX80** - 80:1

### Port threads:

**N** - NPT (*GX025 only*)  
**B** - BSP  
**S** - SAE (*US Standard*)

### Dynamic fluid seals:

**C** - Carbon filled PTFE  
**S** - Polyethylene (*Standard on GX05, GX10, GX20 and GX30*)  
**P** - Polyurethane (*Standard on GX40, GX60 and GX80*)  
**O** - Special options upon request

### Static fluid seals:

**N** - Nitrile  
**V** - Viton (*Standard on all GX pumps*)  
**E** - EPDM Ethylene Propylene

### Pump configuration:

**00** - Basic Pump  
**T1** - As 00 Plus Tank Mounting Flange  
**W1** - As 00 Plus Wall Mounting Bracket  
**R1** - Power Pack Including 2.5 l Reservoir & Mounting Bracket  
**R2** - Power Pack Including 4.5 l Reservoir & Mounting Bracket (*Not available with ATEX approved pumps*)  
**R3** - Horizontal Mounting Version of R1  
**R4** - Horizontal Mounting Version of R2 (*Not available with ATEX approved pumps*)

### Manifold options:

**M** - Pump With CETOP03/D03/NG6 Manifold fitted. Valves mount in vertical plane (*GX10 to GX80 only*)  
**H** - Pump with CETOP03/D03/NG6 Manifold fitted. Valves mount in horizontal plane. (*GX10 to GX40 only*)  
**H2** - Pump with 2 station CETOP03/D03/NG6 Manifold fitted. Valves mount in horizontal plane. (*GX10 to GX40 only*)

### Water option:

**W** - Pump for use with water (*GX05 to 80 only*)  
 Standard GX025 is water compatible

### Design modifications:

**DM\*\*** (e.g DM14 - Low Temperature Seals.)  
 Other options upon request

## KR PUMP RANGE

**E KR40- B P V- 00 M-W-DM\*\***

**E\*\* ATEX Approved** to Ex II 2 G D,c T6 (85) – Omit if standard pump required.

### Fluid/air pressure ratio:

**KR02** - 2:1    **KR05** - 5:1  
**KR10** - 10:1    **KR20** - 20:1  
**KR40** - 40:1    **KR80** - 80:1

### Port threads:

**B** - BSP  
**S** - SAE (*US Standard*)

### Dynamic fluid seals:

**C** - Carbon filled PTFE  
**S** - Polyethylene  
**P** - Polyurethane  
**O** - Special options upon request

### Static fluid seals:

**V** - Viton (*Standard*)  
**E** - EPDM Ethylene Propylene

### Pump configuration:

**00** - Basic pump  
**T2** - As 00 Plus Tank Mounting Flange  
**W3** - As 00 Plus Wall Mounting Brackets  
**R5** - 2.5 l Reservoir & Mounting Bracket (*Not available with ATEX approved pumps*)  
**R5ST** - 3.0 l Steel Reservoir & Mounting Bracket

### Manifold options:

**M2** - Pump with CETOP02/D02/NG4 Manifold Fitted. Valve mounts in vertical plane.  
**M2H** - Pump with CETOP02/D02/NG4 Manifold Fitted. Valve mounts in horizontal plane.  
**M3** - Pump with CETOP03/D03/NG6 Manifold Fitted. Valve mounts in vertical plane.  
**M3H** - Pump with CETOP03/D03/NG6 Manifold Fitted. Valve mounts in horizontal plane.

### Water option:

**W** - Pump for use with water

### Design modifications:

**DM\*\*** (e.g DM27 - Liquid Gas Application Pump)  
 Other options upon request.

If you require more information or assistance with ordering codes please contact your distributor



**NSL** NSL Technology Resources (s) Pte Ltd

No 280 Woodlands Industrial Park E5,  
 #09-11 Harvest @ Woodlands,  
 Singapore 757322

Tel : +65 67957477, 7747 Fax : +65 63162368

Email : sales@nsltechnology.com

