

# LOW-COST IN-LINE FILTERS

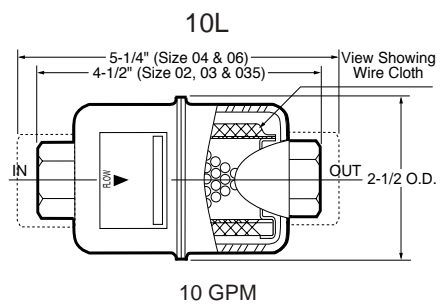
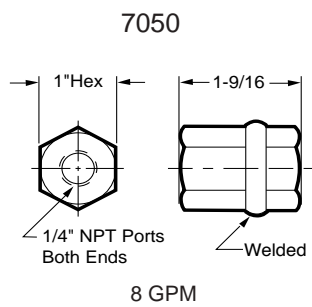

### FOR 8 GPM

The 7050 In-Line Filter is rated at 8 gpm. Stainless steel wire cloth elements are cleanable by backflushing.

### FOR 10 GPM

The 10L In-Line Filter is rated at 10 gpm (suction), 200 psi operating pressure, these filters are used on lubrication and hydraulic systems. Stainless steel elements are cleanable by backflushing. Synthetic depth-type elements are for throwaway use, and give finer filtration.

Housings are sealed canisters of carbon steel or stainless steel and contain 50 square inches of element over an inner support tube. Female NPT fittings are at both inlet and outlet. Options available are integral bypass valves and magnetic bands.

### HOW TO ORDER - 8 GPM

STYLE	ELEMENT
7050	01 238 Micron
	02 74 Micron
	03 40 Micron
	05 149 Micron
	09 25 Micron
	10 10 Micron

### HOW TO ORDER - 10 GPM

Select the desired specifications from the ordering table and build an ordering code number, as shown in this sample:

**10L - 03 - 595 - RV-5 - M - CS**  
 STYLE - NPT - ELEMENT - VALVE - MAGNETS - MATERIAL  
 (omit if not wanted)

STYLE	NPT (Pipe)	ELEMENT (Mesh or Micron)	VALVE (Optional)	MAGNETS (Optional)	MATERIAL
10L	02 (1/4)	Stainless Wire:	RV-3 (3-psi)	M	CS Carbon Steel
	03 (3/8)	585	RV-5 (5-psi)		
	04 (1/2)	238	RV-15 (15-psi)	SS* Stainless	
	06 (3/4)	149			
	03S (3/4-16)	74			
		40			
		25			
	Synthetic:				
	15A (micron)				
	40A (micron)				

\*Available in 06 size only



Style 10L



Style 7050