

Company presentation | product overview

Company history

The family-run company JESSBERGER headquartered in Ottobrunn near Munich is manufacturer of electric and pneumatic driven drum- and container pumps, vertical and horizontal eccentric screw pumps, dosing pumps for high viscous media, hand operated pumps and a comprehensive range of accessories like flowmeters, nozzles, etc.

Air operated diaphragm pumps, horizontal centrifugal pumps (also available as magnetically coupled seal-less centrifugal pumps) and vertical centrifugal pumps complete the delivery program beside further industrial pumps.

Due to long time employees and the firm owners the company can



look back on a long and substantial experience in pump business. Although the name JESSBERGER exists as a firm name in drum pump business only since beginning 2003 the company has developed within a short time to a real alternative. The intention was to set new standards in price at coexisting highest quality – what was succeeded impressively.

Since March 2008 the pump manufacturer has its new head office in Ottobrunn. More than 500 sqm production/stock and 300 sqm office will ensure a further sustained economic growth and the possibility to fulfill special customers' requests. The construction

and production of the eccentric screw pumps occurs at a second facility in Upper Bavaria.



The good reputation of JESSBERGER in drum pump business is a result of a personal, expert advice through our employees, a maximum flexibility in all areas of the company and a direct contact to the customers. The company owners have set themselves the goal of having a very close and personal contact to their customers – not only by exhibiting on many trade shows each year. Furthermore they want to demonstrate their flexibility that is based on a clear arranged company structure at delivery times and special customers' requests. Qualified partners in the Federal Republic of Germany, Europe and all over the world complete this concept and guarantee a nearly optimized customer support.

The company leadership and the technical management attach the greatest importance to a strict quality control. The complete produc-

tion and assembling area is organized in accordance to the quality management system DIN EN ISO 9001:2008 and for the Stainless Steel pump tubes, the electric ex-motor JP-400, the air driven motors JP-AIR1, JP-AIR 2 and JP-AIR 3 and some eccentric screw pumps in accordance to ATEX 100 a (explosion prevention and protection).

Annual external and internal inspection audits assure the compliance with these regulations and ensure the high quality standards. This pronounced awareness of quality and the experience for decades in drum pump business guarantee a high quality of the pumps at a very attractive price.

Convince yourself of the advantages of JESSBERGER and the quality made in Germany.

Product overview

Drum and container pumps with electric or air driven motors (also as laboratory pumps or ATEX certified)

can be used for nearly all kind of media whether thin fluid or middle viscous (max. 1.000 mPas), neutral or aggressive, flammable or non easily combustible.

- Electric universal motors in 230, 115, 12 or 24 Volt in different power and protection classes
- Air driven motors (for max. 6 bar operating pressure)
- Pump tubes in PP, PVDF, Aluminium or Stainless Steel
- Flow rates up to 120 l/min (with 1" hose)
- Pressure up to 3.8 bar (with impeller for high pressure)
- Mixing pump tubes or complete drum emptying as an option
- Pump tube lengths in 700, 1.000, 1.200, 1.500, 1.800 mm
- Special lengths from 200 mm up to 3.000 mm on request



Vertical eccentric screw pumps with single phase or air driven motors (also ATEX certified)

are suitable for a gentle and low-pulsation transferring of thin fluid up to viscous media (max. 20.000 mPas) out of drums and containers. They will be used as portable or stationary pumps for short operation times.

- Electric universal motors in 230 and 115 Volt or air driven motors (for max. 6 bar operating pressure)
- Pump tubes in Stainless Steel 316 Ti
- Stators made of NBR, NBR light, Viton, PTFE, EPDM or Hypalon (depending on the type of medium)
- Standard flow rates of 12, 25 or 50 l/min.
- Discharge pressures of 6 (one stage) or 12 bar (two stages)
- Pump tube lengths in 700, 1.000, 1.200 mm
- Special tube lengths and models on request

Eccentric screw pumps with three phase, gear or air driven motors (also ATEX certified)

are suitable for a gentle and low-pulsation transferring of thin fluid up to high viscous media (max. 100.000 mPas) out of drums and containers. They will be used particularly as stationary pumps and especially for continuous operation times.

- Three phase, gear or air driven motors in different power and protection classes
- Pump tubes in Stainless Steel 316 Ti
- Stators made of NBR, NBR light, Viton, PTFE, EPDM or Hypalon (depending on the type of medium)
- Flow rates of 12, 25 or 50 l/min. at drum pump or 80, 200 or 300 l/min. at container pump
- Discharge pressures of 6 (one stage) or 12 bar (two stages)
- Pump tube lengths in 700, 1.000, 1.200 mm (drum pump) or 1.000, 1.200, 1.500 mm (container pump)
- Special tube lengths and models on request

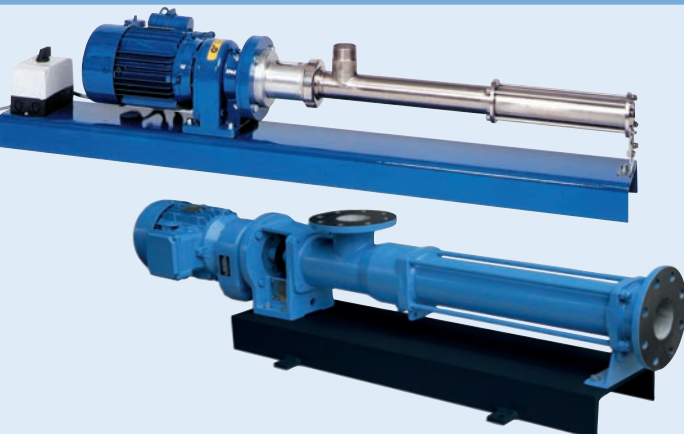

Horizontal eccentric screw pumps with three phase, gear or air driven motors

provide a gentle, low-pulsation transferring of thin fluid up to high viscous (max. 100.000 mPas), thixotropic, gas containing, particles or fibres containing, aggressive or neutral media. These pumps will be used particularly as stationary pumps and especially for continuous operation times.

- Three phase, gear or air driven motors in different power and protection classes
- Pumps in Stainless Steel 316 Ti or cast iron
- Stators made of NBR, NBR light, Viton, PTFE, EPDM or Hypalon (depending on the type of medium)
- Flow rates up to 200 m³/h
- Discharge pressures of 6, 12, 18 or 24 bar



High viscosity dosing pumps

are especially suitable for a low-pulsation transferring and dosing of thin fluid up to high viscous media (max. 100.000 mPas), thixotropic, gas containing, particles or fibres containing, aggressive or neutral media.

- Gear motor suitable for operation with frequency inverter or gear motor that is adjustable via hand
- Pumps in Stainless Steel 316 Ti
- Stators in NBR, NBR light, Viton, PTFE, EPDM or Hypalon (depending on the type of medium)
- Flow rate from 0,6 up to 600 l/h
- Discharge pressures of 6 (one stage) or 12 bar (two stages)

Drum emptying systems

are suitable for a clean and fast emptying of open drums and containers with high viscous up to pasty media that can not flow by itself into the pump any more.

- At this barrel discharge unit a vertical eccentric screw pump with flanged follower plate will be dropped down into the barrel.
- The elastic lip seal of the follower plate strips the inner wall of the drum and enables an optimal emptying. The residue of liquid inside the drum is less than 1% of barrel capacity.

Complete filling systems

are based on the principle of an eccentric screw pump and enable an exact filling of small quantities.

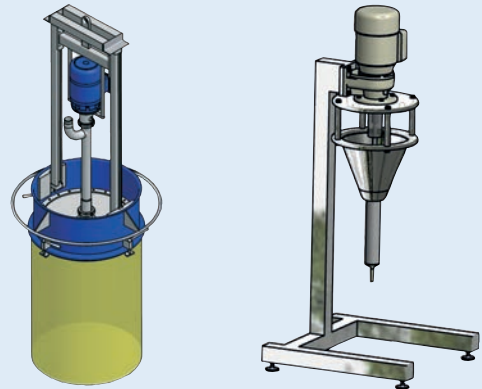

Spare parts for eccentric screw pumps

At wear parts a short delivery time is important as well as quality and price. Our program of spare parts for nearly all well known third parties includes:

- Rotors and stators
- Drive shafts and coupling rods
- Turning work pieces in different materials
- Mechanical seals, glands or o-rings, etc.

Manually hand operated pumps

are light and handy devices for an easy and safe emptying of thin fluid up to middle viscous media (max. 1.000 mPas) out of small canisters or 60 and 200 liter drums.

- Designed as hand lever or rotating pump
- Different pump materials and seals depending on the medium.
The hand operated pumps can be divided in following groups:
 1. For acids and alkalis
 2. For non flammable mineral oil products
 3. For easy flammable media like solvents
 4. For food and beverage products
- Pump tube lengths for canisters and drums
- Flow rates from 0,3 l/stroke up to 1 l/rotation
- Drum adapter with male thread G 2", adapters available

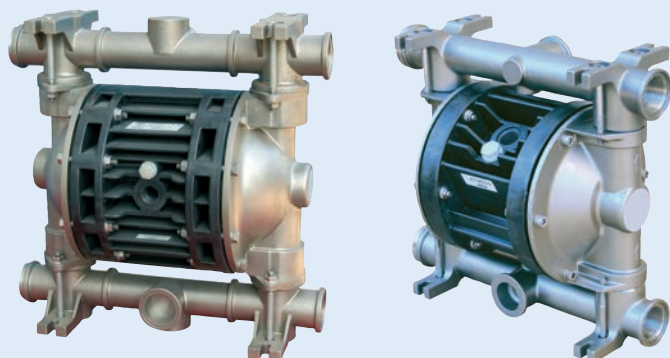

Air operated diaphragm pumps

are suitable for nearly all areas of use. They are self priming, can run dry and are capable of pumping aggressive, flammable and viscous media (max. 50.000 mPas, depending of type of pump), also with particles or media containing gas.

- Pump bodies in PP, PVDF, Aluminium or Stainless Steel
- Flow rates from 5 l/min. (1/4") up to 900 l/min. (3")
- Max. operating pressure of 7 bar
- Transformation ratio 1:1, special type series with ratio 2:1 or 3:1 as high pressure pumps for filter presses
- Certificate for ex-zone 2, conduct version for ex-zone 1
- Special executions for food and sanitary products industry

Horizontal centrifugal pumps with mechanical seal

- Three phase motor, 230/400 Volt, 50 Hz, IP 55, 2900 rpm
- Pump bodies in Polypropylene or PVDF
- Flow rates from 6 up to 75 m³/h
- Delivery head up to 38 m
- Maximum viscosity 500 mPas (at 20 °C)
- Special models (bigger flow rates, pumps made of Stainless Steel, self priming, dry running or ex-protected pumps) on request

Magnetically coupled seal-less centrifugal pumps

- Pump bodies in Polypropylene or PVDF
- Flow rates depending on pump model and type series
- Special models on request



Vertical centrifugal pumps

are especially suitable for a fast transfer of chemicals when emptying containers or tanks. The availability of different materials of construction – depending on chemical and thermal resistance of medium or environment – guarantees an absolute reliability of operation as well as a long life time of pump.

- Three phase motor, 230/400 Volt, 50 Hz, IP 55, 2900 rpm
- Pump bodies in Polypropylene or PVDF
- Pump tube lengths 250, 500, 800, 1.000, 1.250 mm
- Flow rates from 6 up to 75 m³/h
- Delivery head up to 38 m
- Maximum viscosity 500 mPas (at 20 °C)
- Special tube lengths and models (f.e. Stainless Steel) on request

Diesel- and heating oil pumps

are especially suitable for refueling the motors of vehicles that are driven with diesel like tractors, agricultural machines and machines for construction work, trucks and motor boats. They also facilitate the filling of heating oil for heating.

- Protank 25 (at the beginning non self priming)
- Protank 50 (self priming)
- Pump models in 230, 12 and 24 Volt
- Flow rates from 38 up to 52 l/min.
- Delivery head from 9 up to 17 m
- Set with 1,6 m suctions hose, 4 m discharge hose and nozzle (manual or automatic one)
- Flowmeters as an option



Accessories for pumps

- Drum adapters, emission proof adapters, thread adapters
- Strainers made of PP or Stainless Steel (for protection of drum pump if particles are present)
- Manual nozzles made of PP, PVDF, Aluminium or Stainless Steel, automatic nozzles for fuel or diesel
- Hoses in different materials for transferring nearly all kind of media (PVC-hoses, Universal chemical and solvent hoses, mineral oil and food grade hoses, etc.)
- Turbine wheel or oval gear flowmeters made of PP, PVDF, Aluminium or Stainless Steel (also ex-protected), impulse output or preselection of flow rate for controlling a pump or magnetic valve