

Compact Discharge Filter Silencer

EFS Series 3/8" - 1", NW16 - NW25

Features

- Compact design combines both filtration efficiency and noise reduction
- Integrated inlet diffuser optimizes sound attenuation
- Multi-stage noise reducing features including final stage sound absorbent insert
- Tubular silencing design - tube is positioned to maximize attenuation and air flow while minimizing pressure drop
- Patented high grade element with built-in Butterfly gasket seal which creates positive seal between housing hemispheres and a new seal with each element
- Seamless drawn housings
- Corrosive resistant black powder coat carbon steel
- Ability to mount vertically, horizontally

Technical Specifications

- Temp (continuous): min -26°C (-15°F) max 104°C (220°F)
- Polyester: 99%+ removal efficiency standard to 25 micron

Options

- Various media for different environments
- Straight through configuration
- Various nonstandard finishes and connection styles

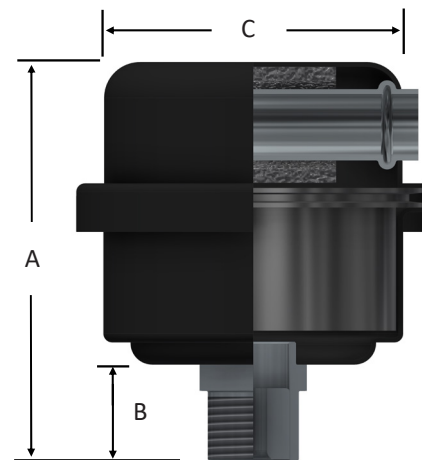

Inlet/Outlet		Assembly m ³ /h Rating	Assembly Part Number	Dimensions - mm			Suggested Service ht. mm	Approx. Weight (kg)	Replacement Element Part No.
Size	Type			A	B	C			
3/8"	MPT	4	EFS-05-038/1	70	17	64	25	0.23	05
1/2"	MPT	16	EFS-07-050/1	95	22	83	51	0.34	07
NW16	ISO Flg	16	EFS-07-NW16/1	95	22	83	51	0.34	07
NW25	ISO Flg	19	EFS-07-NW25/1	95	22	81	51	0.34	07
1"	MPT	41	EFS-11-100/2	114	22	83	51	0.57	11
NW25	ISO Flg	40	EFS-11-NW25/2	114	22	105	51	0.57	11

Rev: EFS-EU2002N

Technical Data

Inlet Filter Silencers, Silencers

Applications & Equipment

- Industrial & Severe Duty
- Blowers - Side Channel & Roots (P.D.)
- Breathers
- Fuel Cells
- Piston Compressors
- Screw Compressors
- Centrifugal Compressors
- Hydraulic Breathers – fine filtration
- Engines
- Fans
- Vacuum Pumps & Systems
- Construction\Contractor Industry
- Medical
- Pneumatic Conveying
- Waste Water Aeration
- Sparging
- Factory Air
- Vacuum Vent Breathers
- Cement Processing
- Power Plants
- Centralized Air Intakes

Identification

Standard Solberg assemblies should have an identification label/nameplate that gives the following information:

- Assembly Model #
- Replacement Element #

The part number designates the filter type, the element configuration and housing connection size. For example, the following part number identifies the filter as being an “FS” design filter with a “275” element, “P” prefilter and 3” BSPT connection size.

FS-275P-301

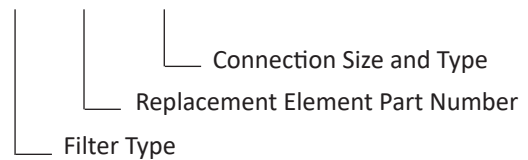

Typical Noise Attenuation

See chart for typical noise attenuation for filter silencers. It may vary due to the wide range of applications, installations, and machines.

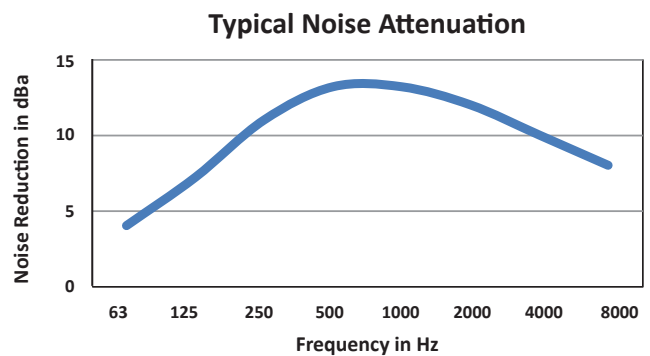

Rev: InletFSTech-EU0719K

Inlet Filter Silencers, Silencers

Choosing the Best Filter for Your Equipment

A. When the connection & airflow is known:

1. select the appropriate connection style. (i.e.: BSPT, Flange, BSPP, etc.)
2. check assembly m^3/hr (flow) rating. Compare with your required airflow.

(Note: Assembly flow ratings are based on 6,000 FPM or 30m/sec for a given connection size to achieve low pressure drop performance. When required flow exceeds assembly flow rating, the pressure drop through the outlet connection will increase. In such cases select by element m^3/hr (flow) rating.)

3. when required flow rating matches connection size; skip to "C. Selecting Elements".

B. When the connection size is unknown, flexible, or the required flow rating exceeds assembly flow rating:

1. match required flow rating with the element flow rating.
2. choose related connection size.

C. Selecting Elements: The filter performance is influenced by the actual application duty and the equipment it is installed on. Regular maintenance checks and proper servicing is required.

Application Duty Descriptions:

Industrial Duty: clean workshop or clean outdoor environment - small element sizing is sufficient.

Severe Duty: dirty workshop, wastewater – medium to large element is recommended.

Extreme Duty: cement, steel making, plastics or dusty material conveying – largest element sizing is recommended.

1. Select media required by your application. Options include:

a. Standard media

1. Polyester: all purpose; withstands pulses, moisture, and oily air
2. Paper: mostly dry, smooth flow applications

b. Special media: for a variety of micron levels and media types, see the "Filter Media Specifications" in the Replacement Element Section or contact Solberg.

2. Select element size by matching the element with the anticipated duty and upsize accordingly.

Filter Assembly Maintenance

Request the appropriate maintenance manual for more in-depth information from your Solberg representative or on our website www.solbergmfg.com.

Element Maintenance

Solberg elements should be replaced once the pressure drop reaches 37-50 mbar above the initial pressure drop of the installation. Cleaning the element is also an option.

Solberg recommends replacing dirty elements for optimal performance. Any damage which results from by-pass or additional pressure drop created by element cleaning is the sole responsibility of the operator.

Note: The overall performance of a filter element is altered once cleaned. The initial pressure drop after subsequent cleanings will be greater than the original, clean pressure drop of the element. After each cleaning, the pressure drop will continue to increase. Under all circumstances, the initial pressure drop of the element needs to be maintained at less than 37 mbar.

If the pressure drop exceeds 50 mbar at start-up, it should be replaced with a new element. With many types of equipment, the maximum pressure drop allowed will be dictated by the ability of the equipment to perform to its rated capacity. Under all circumstances, the operator should avoid exceeding the manufacturer's recommended maximum pressure drop for their specific equipment.



All model offerings and design parameters are subject to change without prior notice.
Contact your representative or Solberg for the most current information.

www.nsltechnology.com

NSL Technology Resources (s) Pte Ltd
No 280 Woodlands Industrial Park E5,
#09-11 Harvest @ Woodlands,
Singapore 757322
Tel : +65 67957477, 7747 Fax : +65 63162368
Email : sales@nsltechnology.com