

Compact Inlet Filters

F Series 1/2" - 6"

Features

- Fully drawn weatherhood
- Low entry velocity air gap between base and cover
- Heavy gauge base with low pressure drop outlet pipe and center bracket design
- Corrosive resistant gray powder coat carbon steel

Technical Specifications

- Temp (continuous): min -15°F (-26°C) max 220°F (104°C)
- Filter change out differential: 15-20" H₂O over initial ΔP
- Pressure drop graphs available upon request
- Polyester: 99%+ removal efficiency standard to 5 micron
- Paper: 99%+ removal efficiency standard to 2 micron

Options

- Tap holes available
- Pressure drop indicator
- Various media for different environments
- Stainless steel construction
- Various nonstandard finishes and connection styles



Threaded Outlet Assembly



Flange Outlet Assembly

Rev: F .5-6-US1903K

F Series 1/2" - 6"

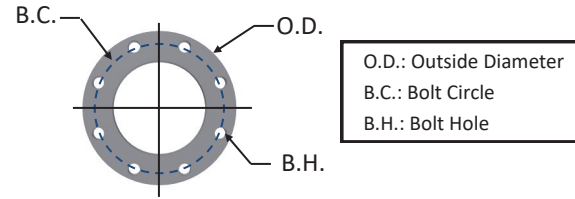
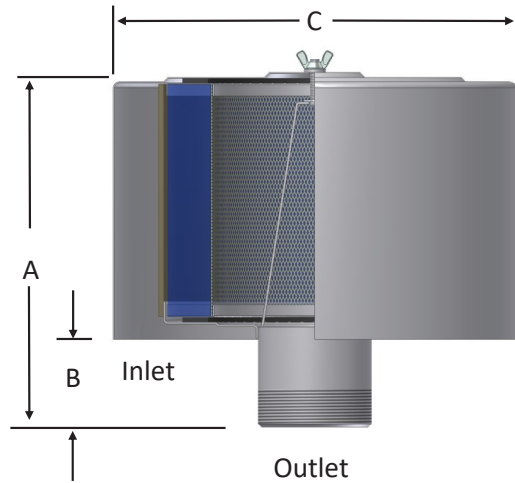

125/150# Pattern Flange	Dimensions - inches			No. of Holes	Flange Thickness
	O.D.	B.C.	B.H.		
4"	9	7 1/2	0.75	8	0.5
5"	10	8 1/2	0.88	8	0.5
6"	11	9 1/2	0.88	8	0.5

MPT Outlet	Assembly SCFM Rating	Assembly Part Number		Dimensions - inches			Suggested Service ht. inches	Approx. Weight lbs.	Replacement Element Part No.		Element SCFM Rating
		Polyester	Paper	A	B	C			Polyester	Paper	
1/2"	10	F-15-050	F-14-050	3 3/8	7/8	6	3	2	15	14	35
3/4"	25	F-15-075	F-14-075	3 3/4	1 1/4	6	3	2	15	14	35
1"	35	F-15-100	F-14-100	3 3/4	1 1/4	6	3	2	15	14	35
1"	55	F-19P-100	F-18P-100	6 1/2	1 1/4	6 1/8	5	3	19P	18P	100
1 1/4"	70	F-19P-125	F-18P-125	7	1 3/4	6 1/8	5	3	19P	18P	100
1 1/2"	85	F-19P-150	F-18P-150	7	1 3/4	6 1/8	5	3	19P	18P	100
2"	135	F-31P-200	F-30P-200	7 5/16	2 1/4	7 7/8	5	5	31P	30P	195
2"	135	F-231P-200	F-230P-200	12	2 1/4	10 1/4	6	12	231P	230P	300
2 1/2"	195	F-31P-250	F-30P-250	8	3	7 7/8	5	6	31P	30P	195
2 1/2"	195	F-231P-250	F-230P-250	12 1/2	2 1/2	10 1/4	6	13	231P	230P	300
3"	300	F-231P-300	F-230P-300	12 3/4	3	10 1/4	6	14	231P	230P	300
3"	300	F-235P-300	F-234P-300	12 3/4	3	10 1/4	10	15	235P	234P	570
3"	300	F-275P-300	F-274P-300	13 5/16	3	18	10	24	275P	274P	1100
4"	520	F-235P-400	F-234P-400	13 11/16	4	10 1/4	10	15	235P	234P	570
4"	520	F-245P-400	F-244P-400	14	4	12	10	22	245P	244P	880
4"	520	F-275P-400	F-274P-400	14 1/8	4	16	10	26	275P	274P	1100
5"	800	F-245P-500	F-244P-500	13 13/16	4	12	10	23	245P	244P	880
5"	800	F-275P-500	F-274P-500	14	4	16	10	27	275P	274P	1100
6"	1100	F-275P-600	F-274P-600	15 1/8	5	16	10	29	275P	274P	1100

Flange Outlet	Assembly SCFM Rating	Assembly Part Number		Dimensions - inches			Suggested Service ht. inches	Approx. Weight lbs.	Replacement Element Part No.		Element SCFM Rating
		Polyester	Paper	A	B	C			Polyester	Paper	
4"	520	F-235P-400F	F-234P-400F	13 11/16	4	10 1/4	10	20	235P	234P	570
4"	520	F-245P-400F	F-244P-400F	14	4	12	10	27	245P	244P	880
4"	520	F-275P-400F	F-274P-400F	14 1/8	4	16	10	31	275P	274P	1100
5"	800	F-245P-500F	F-244P-500F	13 13/16	4	12	10	27	245P	244P	880
5"	800	F-275P-500F	F-274P-500F	13 7/8	4	16	10	32	275P	274P	1100
6"	1100	F-275P-600F	F-274P-600F	15 1/8	5	16	10	34	275P	274P	1100

See Filter Assembly Technical Data for sizing guidelines.



SOLBERG®

All model offerings and design parameters are subject to change without prior notice.
Contact your representative or Solberg for the most current information.

www.nsltechnology.com

Big Boy Inlet Filters

F Series 6" - 24"

Features

- Heavy gauge base with low pressure drop outlet pipe and center bracket design
- Low entry velocity air gap between base and cover
- Corrosive resistant gray powder coat carbon steel

Technical Specifications

- Temp (continuous): min -15°F (-26°C) max 220°F (104°C)
- Filter change out differential: 15-20" H₂O over initial Δ P
- Pressure drop graphs available upon request
- Polyester: 99%+ removal efficiency standard to 5 micron
- Paper: 99%+ removal efficiency standard to 2 micron

Options



- Tap holes available
- Pressure drop indicator
- Various media for different environments
- Stainless steel construction
- Various nonstandard finishes and connection styles

Sumo Class Features

- Single barrel filter design allows for large airflows in space restricted work areas
- 16" to 24" flange connections available
- Designed for airflows up to 8000 SCFM

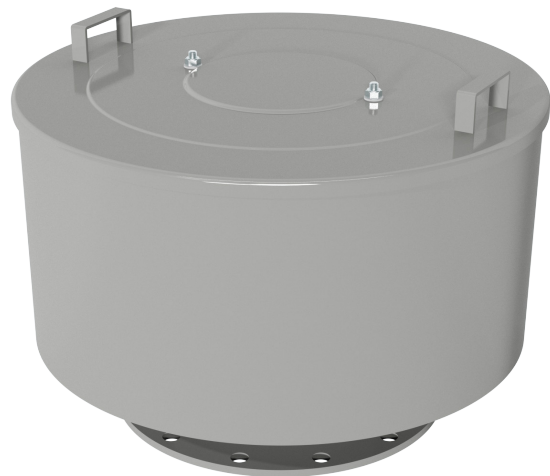

Rev: F 6-24-US1903K

F Series 6" - 24"

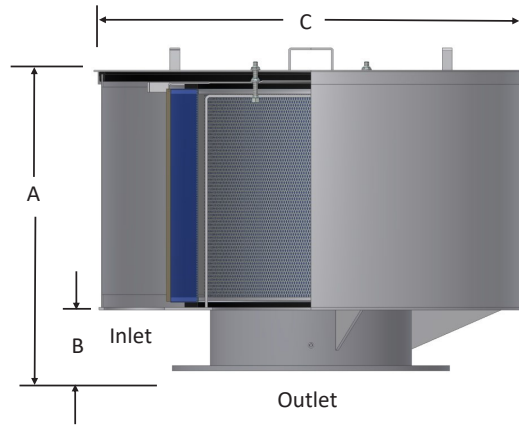

Flange Outlet	Assembly SCFM Rating	Assembly Part Number		Dimensions - inches			Suggested Service ht. inches	Approx. Weight lbs	Replacement Element Part No.		Element SCFM Rating
		Polyester	Paper	A	B	C			Polyester	Paper	
6"	1100	F-377P-600F	F-376P-600F	22	5	21 7/8	15	90	377P	376P	1825
8"	1800	F-377P-800F	F-376P-800F	22 7/8	6	21 7/8	15	100	377P	376P	1825
8"	1800	F-385P-800F	F-384P-800F	23	6	28 5/16	15	125	385P	384P	3295
10"	3300	F-385P-1000F	F-384P-1000F	22 7/8	6	28 5/16	15	130	385P	384P	3295
10"	3300	F-485P-1000F	F-484P-1000F	29 13/16	6	28 5/16	22	143	485P	484P	4705
12"	4700	F-485P-1200F	F-484P-1200F	30	6	28 5/16	22	155	485P	484P	4705
12"	4700	F-685P-1200F	F-384P(2)-1200F	38 1/2	6	28 5/16	29	175	685P	384P(2)	6600
14"	6000	F-485P(2)-1400F	F-484P(2)-1400F	53 1/2	6	28 5/16	22	245	485P(2)	484P(2)	9410

Flange Outlet	Assembly SCFM Rating	Assembly Part Number		Dimensions - inches			Suggested Service ht. inches	Replacement Element Part No.	
		Polyester	Paper	A	B	C		Polyester	Paper
18"	5500	F-391-1800F	F-390-1800F	23 1/2	6	36	15	391	390
18"	8000	F-491-1800F	F-490-1800F	30 1/2	6	36	22	491	490
20"	8000	F-491-2000F	F-490-2000F	30 1/2	6	36	22	491	490
24"	8000	F-491-2400F	F-490-2400F	30 1/2	6	36	22	491	490

125/150# Pattern Flange	Dimensions - inches			No. of Holes	Flange Thickness
	O.D.	B.C.	B.H.		
6"	11	9 1/2	0.88	8	0.5
8"	13 1/2	11 3/4	0.88	8	0.5
10"	16	14 1/4	1	12	0.5
12"	19	17	1	12	0.5
14"	21	18 3/4	1 1/8	12	0.5
18"	25	22 3/4	1 1/4	16	0.5
20"	27 1/2	25	1 1/4	20	0.5
24"	32	29 1/2	1 3/8	20	1.18

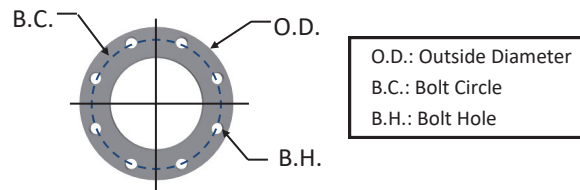

O.D.: Outside Diameter
B.C.: Bolt Circle
B.H.: Bolt Hole

See Filter Assembly Technical Data for sizing guidelines.



SOLBERG®

All model offerings and design parameters are subject to change without prior notice. Contact your representative or Solberg for the most current information.

www.nsltechnology.com

Technical Data

Inlet Filter Silencers, Silencers

Applications & Equipment

- Industrial & Severe Duty
- Blowers - Side Channel & P.D.
- Breathers
- Fuel Cells
- Piston Compressors
- Screw Compressors
- Centrifugal Compressors
- Hydraulic Breathers – fine filtration
- Engines
- Fans
- Vacuum Pumps & Systems
- Construction\Contractor Industry
- Medical
- Pneumatic Conveying
- Waste Water Aeration
- Sparging
- Factory Air
- Vacuum Vent Breathers
- Cement Processing
- Power Plants
- Centralized Air Intakes

Identification

Standard Solberg assemblies should have an identification label/nameplate that gives the following information:

- Assembly Model #
- Replacement Element #

The part number designates the filter type, the element configuration and housing connection size. For example, the following part number identifies the filter as being an “FS” design filter with a “275” element, “P” prefilter and 3” MPT connection size.

FS-275P-300

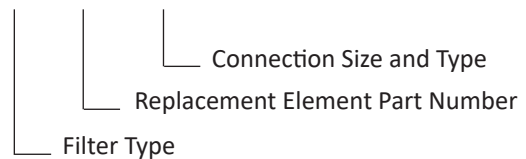

Typical Noise Attenuation

See chart for typical noise attenuation for filter silencers. It may vary due to the wide range of applications, installations, and machines.

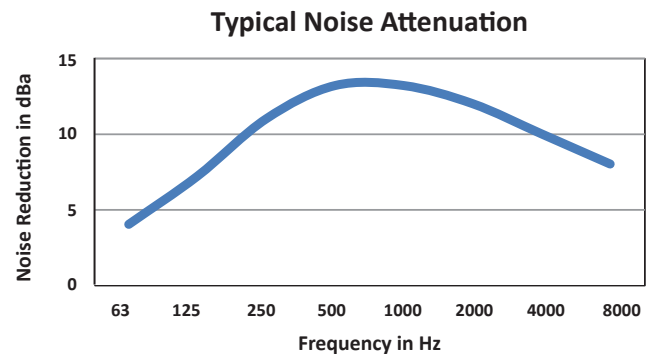

Rev: IFSTD-US1904K

Inlet Filter Silencers, Silencers

Choosing the Best Filter for Your Equipment

A. When the connection & airflow is known:

1. select the appropriate connection style. (i.e.: MPT, Flange, NPSC, etc.)
2. check assembly SCFM (flow) rating. Compare with your required airflow.

(Note: Assembly flow ratings are based on 6,000 FPM or 30m/sec for a given connection size to achieve low pressure drop performance. When required flow exceeds assembly flow rating, the pressure drop through the outlet connection will increase. In such cases select by element SCFM (flow) rating.)

3. when required flow rating matches connection size; skip to "C. Selecting Elements".

B. When the connection size is unknown, flexible, or the required flow rating exceeds assembly flow rating:

1. match required flow rating with the element flow rating.
2. choose related connection size.

C. Selecting Elements: The filter performance is influenced by the actual application duty and the equipment it is installed on. Regular maintenance checks and proper servicing is required.

Application Duty Descriptions:

Industrial Duty: clean workshop or clean outdoor environment - small element sizing is sufficient.

Severe Duty: dirty workshop, wastewater – medium to large element is recommended.

Extreme Duty: cement, steel making, plastics or dusty material conveying – largest element sizing is recommended.

1. Select media required by your application. Options include:

a. Standard media

1. Polyester: all purpose; withstands pulses, moisture, and oily air
2. Paper: mostly dry, smooth flow applications

b. Special media: for a variety of micron levels and media types, see the "Filter Media Specifications" in the Replacement Element Section or contact Solberg.

2. Select element size by matching the element with the anticipated duty and upsize accordingly.

Filter Assembly Maintenance

Request the appropriate maintenance manual for more in-depth information from your Solberg representative or on our website www.solbergmfg.com.

Element Maintenance

Solberg elements should be replaced once the pressure drop reaches 15-20" H₂O above the initial pressure drop of the installation. Cleaning the element is also an option.

Solberg recommends replacing dirty elements for optimal performance. Any damage which results from by-pass or additional pressure drop created by element cleaning is the sole responsibility of the operator.

Note: The overall performance of a filter element is altered once cleaned. The initial pressure drop after subsequent cleanings will be greater than the original, clean pressure drop of the element. After each cleaning, the pressure drop will continue to increase. Under all circumstances, the initial pressure drop of the element needs to be maintained at less than 15" H₂O.

If the pressure drop exceeds 20" H₂O at start-up; it should be replaced with a new element. With many types of equipment, the maximum pressure drop allowed will be dictated by the ability of the equipment to perform to its rated capacity. Under all circumstances, the operator should avoid exceeding the manufacturer's recommended maximum pressure drop for their specific equipment.



All model offerings and design parameters are subject to change without prior notice.
Contact your representative or Solberg for the most current information.

www.nsltechnology.com

NSL NSL Technology Resources (s) Pte Ltd
No 280 Woodlands Industrial Park E5,
#09-11 Harvest @ Woodlands,
Singapore 757322
Tel : +65 67957477, 7747 Fax : +65 63162368
Email : sales@nsltechnology.com