



# Exposed Inlet Filters

**FT Series 1/4" - 6", DN80 - DN300**

## Features

- Exposed element for optimal air flow & low restriction
- Heavy gauge base with low pressure drop outlet pipe and center bracket design
- Corrosive resistant gray powder coat carbon steel

## Technical Specifications

- Temp (continuous): min -26°C (-15°C) max 104°C (220°F)
- Filter change out differential: 37-50 mbar over initial ΔP
- Pressure drop graphs available upon request
- Polyester: 99%+ removal efficiency standard to 5 micron
- Paper: 99%+ removal efficiency standard to 2 micron

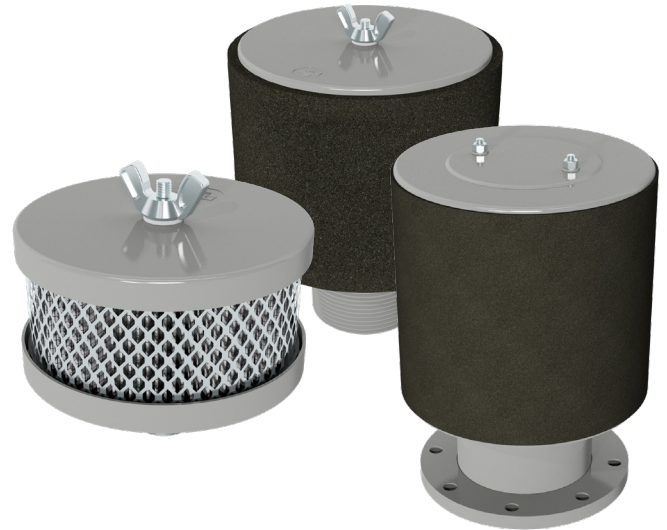

## Options ATEX Available

- Tap holes available
- Pressure drop indicator
- Various media for different environments
- Stainless steel construction
- Various nonstandard finishes and connection styles

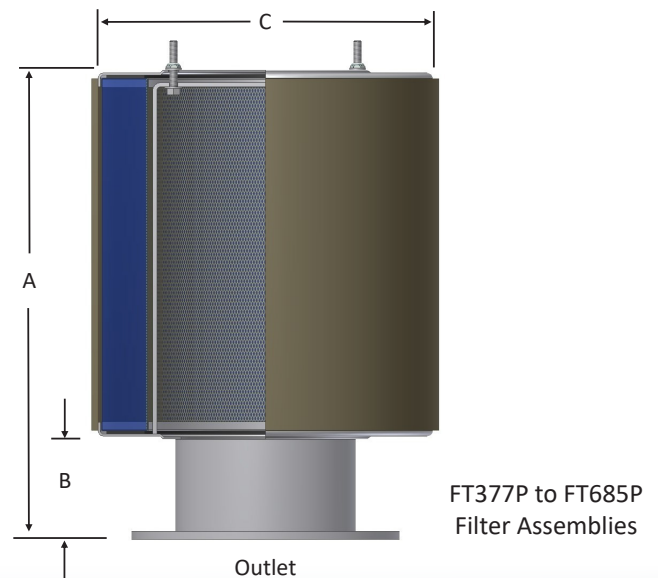
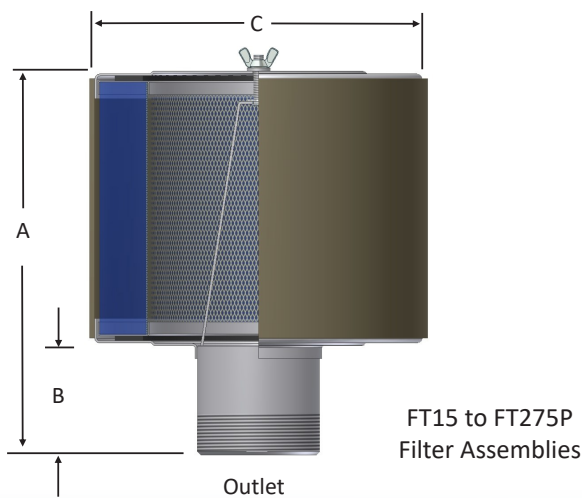

Rev: FT EU1908K

# FT Series 1/4" - 6", DN80 - DN300

Outlet Size	Type	Assembly m <sup>3</sup> /hr Rating	Assembly Part Number		Dimensions - mm			Suggested Service ht. mm	Approx. Weight kg	Replacement Element Part No.		Element m <sup>3</sup> /hr Rating
			Polyester	Paper	A	B	C			Polyester	Paper	
1/2"	MPT	17	FT-15-050	FT-14-050	85	23	117	59	0.54	15	14	60
3/4"	MPT	43	FT-15-075	FT-14-075	93	32	117	59	0.59	15	14	60
1"	MPT	60	FT-15-100	FT-14-100	93	32	117	59	0.63	15	14	60
1"	MPT	94	FT-19P-100	FT-18P-100	157	32	124	121	0.81	19P	18P	170
1 1/4"	BSPT	119	FT-19P-126	FT-18P-126	169	44	124	121	0.81	19P	18P	170
1 1/2"	BSPT	145	FT-19P-151	FT-18P-151	169	44	124	121	0.90	19P	18P	170
2"	BSPT	230	FT-31P-201	FT-30P-201	184	57	165	121	1.35	31P	30P	332
2"	BSPT	230	FT-231P-201	FT-230P-201	301	57	165	241	3	231P	230P	332
2 1/2"	BSPT	332	FT-31P-251	FT-30P-251	191	64	165	121	2	31P	30P	332
2 1/2"	BSPT	332	FT-231P-251	FT-230P-251	308	64	165	241	3	231P	230P	510
3"	BSPT	510	FT-231P-301	FT-230P-301	320	76	165	241	4	231P	230P	510
3"	BSPT	510	FT-235P-301	FT-234P-301	325	76	229	241	6	235P	234P	970
3"	BSPT	510	FT-275P-301	FT-274P-301	330	76	318	244	10	275P	274P	1870
4"	BSPT	885	FT-235P-401	FT-234P-401	348	102	229	241	8	235P	234P	970
4"	BSPT	885	FT-275P-401	FT-274P-401	356	102	318	244	11	275P	274P	1870
5"	BSPT	1360	FT-275P-501	FT-274P-501	356	102	318	244	11	275P	274P	1870
6"	BSPT	1870	FT-275P-601	FT-274P-601	381	127	318	244	12	275P	274P	1870

Note: MPT threaded housings are interchangeable with BSPT up to 1".

Flange Outlet	Assembly m <sup>3</sup> /hr Rating	Assembly Part Number		Dimensions - mm			Suggested Service ht. mm	Approx. Weight kg	Replacement Element Part No.		Element m <sup>3</sup> /hr Rating
		Polyester	Paper	A	B	C			Polyester	Paper	
DN80	510	FT-235P-DN80	FT-234P-DN80	330	76	203	241	6	235P	234P	970
DN80	510	FT-275P-DN80	FT-274P-DN80	330	76	305	244	10	275P	274P	1870
DN100	885	FT-235P-DN100	FT-234P-DN100	349	102	229	241	7	235P	234P	970
DN100	885	FT-275P-DN100	FT-274P-DN100	356	102	318	244	11	275P	274P	1870
DN125	1360	FT-275P-DN125	FT-274P-DN125	356	102	318	244	13	275P	274P	1870
DN150	1870	FT-275P-DN150	FT-274P-DN150	381	127	318	244	14	275P	274P	1870
DN200	3060	FT-377P-DN200	FT-376P-DN200	584	152	381	368	29	377P	376P	3105
DN200	3060	FT-385P-DN200	FT-384P-DN200	584	152	518	368	32	385P	384P	5605
DN250	5610	FT-385P-DN250	FT-384P-DN250	584	152	518	368	36	385P	384P	5610
DN250	5610	FT-685P-DN250	FT-384P(2)-DN250	890	152	518	724	43	685P	384P(2)	11220
DN300	7990	FT-485P-DN300	FT-484P-DN300	712	152	518	546	41	485P	484P	8000
DN300	7990	FT-685P-DN300	FT-384P(2)-DN300	890	152	518	724	45	685P	384P(2)	11220

See Filter Assembly Technical Data for sizing guidelines.

PN10 Pattern Flange	Dimensions - mm			No. of Holes	Flange Thickness mm
	O.D.	B.C.	B.H.		
DN80	200	160	18	8	20
DN100	220	180	18	8	20
DN125	250	210	18	8	22
DN150	285	240	22	8	22
DN200	340	295	22	8	24
DN250	395	350	22	12	26
DN300	445	400	22	12	26

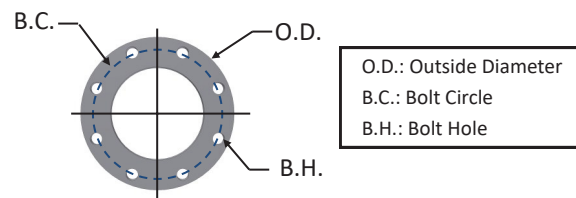

**SOLBERG®**

All model offerings and design parameters are subject to change without prior notice.  
Contact your representative or Solberg for the most current information.

[www.nsltechnology.com](http://www.nsltechnology.com)

# Technical Data

## Inlet Filter Assemblies

### Applications & Equipment

- Industrial & Severe Duty
- Blowers - Side Channel & Roots (P.D.)
- Breathers
- Fuel Cells
- Piston Compressors
- Screw Compressors
- Centrifugal Compressors
- Hydraulic Breathers – fine filtration
- Engines
- Fans
- Vacuum Pumps & Systems
- Construction\Contractor Industry
- Medical
- Pneumatic Conveying
- Waste Water Aeration
- Sparging
- Factory Air
- Vacuum Vent Breathers
- Cement Processing
- Power Plants
- Centralized Air Intakes

### Identification

Standard Solberg assemblies should have an identification label/nameplate that gives the following information:

- Assembly Model #
- Replacement Element #

The part number designates the filter type, the element configuration and housing connection size. For example, the following part number identifies the filter as being an “F” design filter with a “385” element, “P” prefilter and DN250 flange connection size.

#### **F-385P-DN250**

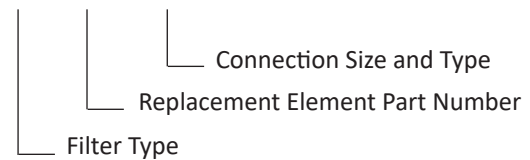

### Typical Flow Curve

See chart for the typical flow curve for inlet filtration housing comparing the percentage of rated flow with typical pressure drop.

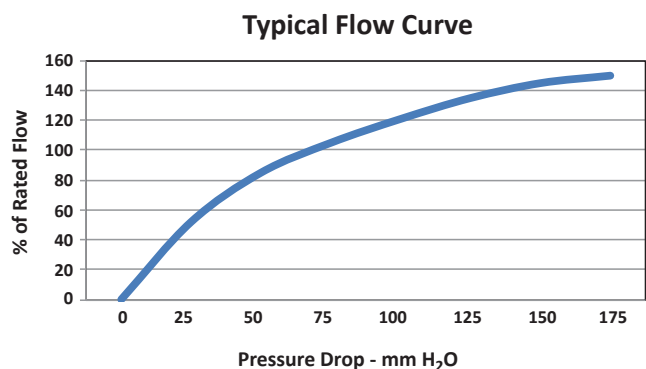

Rev: InletFTech-EU0719K

# Inlet Filter Assemblies

## Choosing the Best Filter for Your Equipment

A. When the connection & airflow is known:

1. select the appropriate connection style. (i.e.: BSPT, Flange, BSPP, etc.)
2. check assembly  $m^3/hr$  (flow) rating. Compare with your required airflow.

(Note: Assembly flow ratings are based on 6,000 FPM or 30m/sec for a given connection size to achieve low pressure drop performance. When required flow exceeds assembly flow rating, the pressure drop through the outlet connection will increase. In such cases select by element  $m^3/hr$  (flow) rating.)

3. when required flow rating matches connection size; skip to "C. Selecting Elements".

B. When the connection size is unknown, flexible, or the required flow rating exceeds assembly flow rating:

1. match required flow rating with the element flow rating.
2. choose related connection size.

C. Selecting Elements: The filter performance is influenced by the actual application duty and the equipment it is installed on. Regular maintenance checks and proper servicing is required.

### **Application Duty Descriptions:**

Industrial Duty: clean workshop or clean outdoor environment - small element sizing is sufficient.

Severe Duty: dirty workshop, wastewater – medium to large element is recommended.

Extreme Duty: cement, steel making, plastics or dusty material conveying – largest element sizing is recommended.

1. Select media required by your application. Options include:

a. Standard media

1. Polyester: all purpose; withstands pulses, moisture, and oily air
2. Paper: mostly dry, smooth flow applications

b. Special media: for a variety of micron levels and media types, see the "Filter Media Specifications" in the Replacement Element Section or contact Solberg.

2. Select element size by matching the element with the anticipated duty and upsize accordingly.

## Filter Assembly Maintenance

Request the appropriate maintenance manual for more in-depth information from your Solberg representative or on our website [www.solbergmfg.com](http://www.solbergmfg.com).

## Element Maintenance

Solberg elements should be replaced once the pressure drop reaches 37-50 mbar above the initial pressure drop of the installation. Cleaning the element is also an option.

Solberg recommends replacing dirty elements for optimal performance. Any damage which results from by-pass or additional pressure drop created by element cleaning is the sole responsibility of the operator.

Note: The overall performance of a filter element is altered once cleaned. The initial pressure drop after subsequent cleanings will be greater than the original, clean pressure drop of the element. After each cleaning, the pressure drop will continue to increase. Under all circumstances, the initial pressure drop of the element needs to be maintained at less than 37 mbar.

If the pressure drop exceeds 50 mbar at start-up, it should be replaced with a new element. With many types of equipment, the maximum pressure drop allowed will be dictated by the ability of the equipment to perform to its rated capacity. Under all circumstances, the operator should avoid exceeding the manufacturer's recommended maximum pressure drop for their specific equipment.



All model offerings and design parameters are subject to change without prior notice.  
Contact your representative or Solberg for the most current information.

[www.nsltechnology.com](http://www.nsltechnology.com)

**NSL** NSL Technology Resources (s) Pte Ltd  
No 280 Woodlands Industrial Park E5,  
#09-11 Harvest @ Woodlands,  
Singapore 757322  
Tel : +65 67957477, 7747 Fax : +65 63162368  
Email : [sales@nsltechnology.com](mailto:sales@nsltechnology.com)