



# Vapour Condensing Separator Trap

## JRS Series 2" - 8"

### Overview

JRS Series vacuum filter systems are designed to protect equipment from harmful vapors and liquids that can break down pump oils and destroy a pump's inner workings. Vapor removal is accomplished through transitioning a substance from a gaseous state to a liquid or solid state and collecting any condensed material that accumulates.

### Features

- Removable heat exchanger fin pack for ease of cleaning and long lasting optimum performance
- Coolant flask system
- Corrosive resistant blue powder coat carbon steel
- Coolant inlet and outlet ports
- 2" BSPP drain port

### Options



- ASME, PED rated vessels
- Stainless steel construction
- Drain systems CE compliant
- Ports, gauges, leg supports
- Davit arm
- Demister
- For removable or unremovable bottom, please contact Solberg

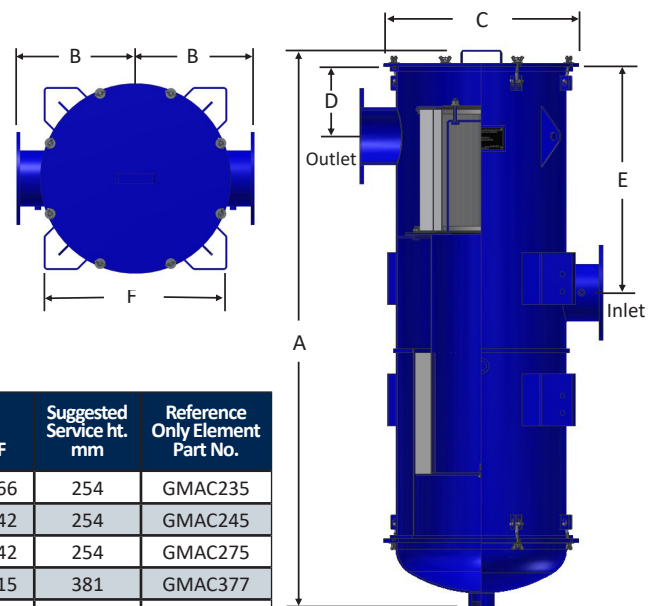

Flange Inlet/Outlet	Reference Assembly m <sup>3</sup> /hr	Reference Only Assembly Part Number	Reference Only Dimensions - mm						Suggested Service ht. mm	Reference Only Element Part No.
			A	B	C	D	E	F		
DN50	243	JRS-GMAC235-DN50	1280	250	340	150	550	466	254	GMAC235
DN80	374	JRS-GMAC245-DN80	1450	300	440	200	625	542	254	GMAC245
DN100	468	JRS-GMAC275-DN100	1461	300	470	200	625	542	254	GMAC275
DN125	774	JRS-GMAC377-DN125	1622	350	540	200	800	615	381	GMAC377
DN150	1403	JRS-GMAC385-DN150	1633	425	572	200	800	688	381	GMAC385
DN200	1998	JRS-GMAC485-DN200	2042	425	640	200	1050	688	559	GMAC485

Contact factory for application details.

Rev: JRS-EU1907K

# Technical Data

## Inlet Vacuum Filters

### Applications & Equipment

- Industrial & Severe Duty
- Vacuum Pumps & Systems: Roots, Rotary Vane, Screw, Piston
- Vacuum Packaging Equipment
- Vacuum Furnace
- Blowers: Side Channel & P.D.
- Vacuum Lifters
- Intake Suction Filters
- Food Industry
- Woodworking/Routers
- Ash Handling
- Printing Industry
- Medical/Hospital
- Remote Installations for Piston & Screw Compressors
- Paper Processing
- Waste Water Aeration
- Cement Processing
- Bag House Systems
- Vacuum Vent Breathers
- Chemical Processing
- Factory Automation Equipment
- Leak Detection Systems

### Identification

Standard Solberg assemblies should have an identification label/nameplate that gives the following information:

- Assembly Model #
- Replacement Element #

The part number designates the filter type, the element configuration and housing connection size. For example, the following part number identifies the filter as being a “CSL” design filter with a “235” element, “P” prefilter and DN100 flange connection size.

#### CSL-235P-DN100

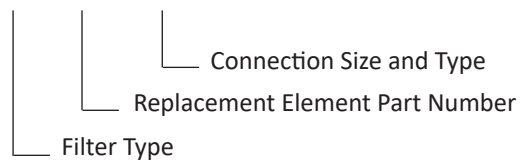

### Vacuum Service Rating Chart

Threaded vacuum filter connections must be free of defect and properly sealed to achieve deeper vacuum levels. Vacuum service levels are given for reference only and serve as a guideline for product selection. Product certification and alternative designs are available for applications requiring deeper vacuum levels and specific leak rates. Please contact factory for details.

Vacuum Level	Pressure (mbar)	Pressure (Torr)	Pressure (Pa)
Atmospheric Pressure	1013	760	1.013x10 <sup>5</sup>
Coarse Vacuum	1013 to 33	760 to 25	1x10 <sup>5</sup> to 3x10 <sup>3</sup>
Medium Vacuum	33 to 1.3x10 <sup>-3</sup>	25 to 1x10 <sup>-3</sup>	3x10 <sup>3</sup> to 1x10 <sup>-1</sup>
High Vacuum	1.3x10 <sup>-3</sup> to 1.3x10 <sup>-9</sup>	1x10 <sup>-3</sup> to 1x10 <sup>-9</sup>	1x10 <sup>-1</sup> to 1x10 <sup>-7</sup>

Rev: InletVacTech-EU0719K

# Inlet Vacuum Filters

## Choosing the Best Filter for Your Equipment

A. When the connection & airflow is known:

1. select the appropriate connection style. (i.e.: BSPT, Flange, BSPP, etc.)
2. check assembly m<sup>3</sup>/hr (flow) rating. Compare with your required airflow.

(Note: Assembly flow ratings are based on 6,000 FPM or 30m/sec for a given connection size to achieve low pressure drop performance. When required flow exceeds assembly flow rating, the pressure drop through the outlet connection will increase. In such cases select by element m<sup>3</sup>/hr (flow) rating.)

3. when required flow rating matches connection size; skip to "C. Selecting Elements".

B. When the connection size is unknown, flexible, or the required flow rating exceeds assembly flow rating:

1. match required flow rating with the element flow rating.
2. choose related connection size.

C. Selecting Elements: The filter performance is influenced by the actual application duty and the equipment it is installed on. Regular maintenance checks and proper servicing is required.

### **Application Duty Descriptions:**

Industrial Duty: clean workshop or clean outdoor environment - small element sizing is sufficient.

Severe Duty: dirty workshop, wastewater – medium to large element is recommended.

Extreme Duty: cement, steel making, plastics or dusty material conveying – largest element sizing is recommended.

1. Select media required by your application. Options include:

a. Standard media

1. Polyester: all purpose; withstands pulses, moisture, and oily air
2. Paper: mostly dry, smooth flow applications

b. Special Media: for a variety of micron levels and media types, see the "Filter Media Specifications" in the Replacement Element Section or contact Solberg.

2. Select element size by matching the element with the anticipated duty and upsize accordingly.

## Filter Assembly Maintenance

Request the appropriate maintenance manual for more in-depth information from your Solberg representative or on our website: [www.solbergmfg.com](http://www.solbergmfg.com).

## Element Maintenance

Solberg elements should be replaced once the pressure drop reaches 37-50 mbar above the initial pressure drop of the installation. Cleaning the element is also an option.

Solberg recommends replacing dirty elements for optimal performance. Any damage which results from by-pass or additional pressure drop created by element cleaning is the sole responsibility of the operator.

Note: The overall performance of a filter element is altered once cleaned. The initial pressure drop after subsequent cleanings will be greater than the original, clean pressure drop of the element. After each cleaning, the pressure drop will continue to increase. Under all circumstances, the initial pressure drop of the element needs to be maintained at less than 37 mbar.

If the pressure drop exceeds 50 mbar at start-up; it should be replaced with a new element. With many types of equipment, the maximum pressure drop allowed will be dictated by the ability of the equipment to perform to its rated capacity. Under all circumstances, the operator should avoid exceeding the manufacturer's recommended maximum pressure drop for their specific equipment.



All model offerings and design parameters are subject to change without prior notice.  
Contact your representative or Solberg for the most current information.

[www.nsltechnology.com](http://www.nsltechnology.com)

**NSL Technology Resources (s) Pte Ltd**  
No 280 Woodlands Industrial Park E5,  
#09-11 Harvest @ Woodlands,  
Singapore 757322  
Tel : +65 67957477, 7747 Fax : +65 63162368  
Email : [sales@nsltechnology.com](mailto:sales@nsltechnology.com)