

# Oil Mist Eliminators

*SME Series*



protecting your equipment • protecting your environment



# SME Mist Eliminator Specifications

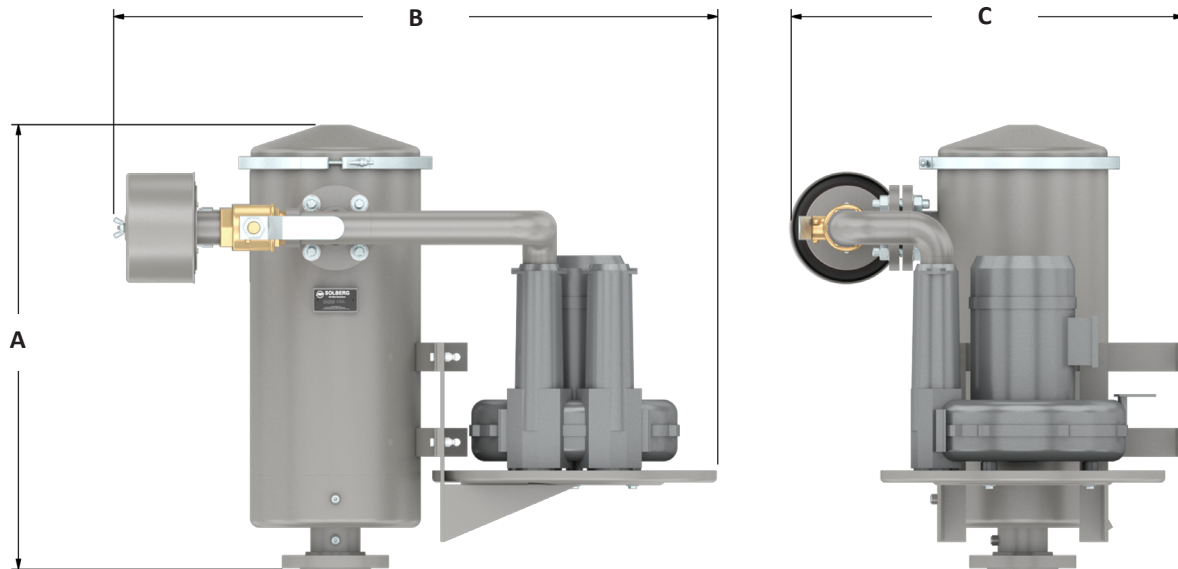

Part #	Flow Rate 50Hz/60Hz	A	B	C	Vacuum Level	Drain Connection	Element	Separator Efficiency	Motor Specs*	Voltage	Horsepower
SME-M-C-A30-MOR	20 / 30 CFM	18.6" 471 mm	30.0" 763 mm	20.4" 517 mm	-1" to -5" WC	0.5" NPT	CEG850/1	99.97% @ 0.3 micron	Class F, TEFC, 40C, IP55	400/460V	0.75 HP 0.56 kW
SME-M-C-A75-MOR	50 / 75 CFM	20.1" 510 mm	35.8" 909 mm	22.4" 568 mm			CEG244/2				1.5 HP 1.13 kW
SME-M-C-A125-MOR	80 / 125 CFM	31.2" 793 mm	37.1" 943 mm	27.5" 699 mm			CEG344/2				2 HP 1.5 kW
SME-M-C-A175-MOR	125 / 175 CFM	31.2" 793 mm	42.4" 1078 mm	27.5" 699 mm			CEG444/2				3 HP 2.25 kW

\*Standard electric motor offering, other options available. Contact factory.

## Optional Configurations

**Recirculation Option**

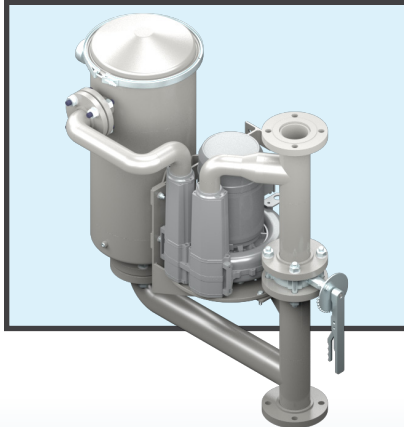

**Custom Motor Option**

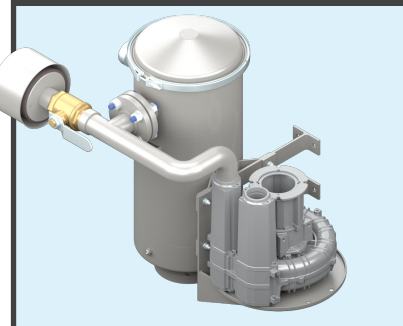

**Bypass Option**

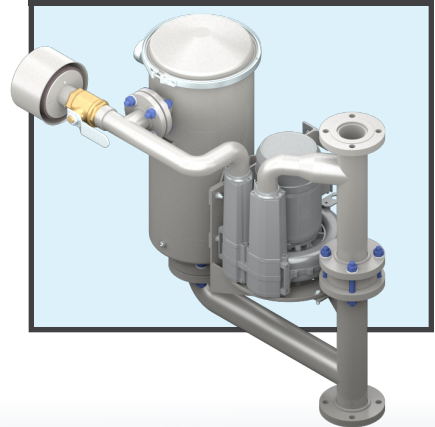



**NSL** NSL Technology Resources (s) Pte Ltd  
No 280 Woodlands Industrial Park E5,  
#09-11 Harvest @ Woodlands,  
Singapore 757322  
Tel : +65 67957477, 7747 Fax : +65 63162368  
Email : sales@nsltechnology.com