

# See-Through Vacuum Filters

## ST Series 1" - 4"

### Features

- Compact design for space restrictions; min. service area
- Inlet above element for extended element life & maintenance intervals
- Corrosive resistant cast aluminum top with machined connections and integrated baffle design
- "T" style design minimizes piping requirements
- Shatter-resistant polycarbonate drop down bucket

### Technical Specifications

- Vacuum Rating: medium vacuum service\*
- Temp (continuous): min -26°C (-15°F) max 104°C (220°F)
- Filter change out differential: 37-50 mbar over initial ΔP
- Polyester: 99%+ removal efficiency standard to 5 micron
- Paper: 99%+ removal efficiency standard to 2 micron

### Options

- Swing bolts for heavy duty environments
- Drain ports
- Spool piece extender (select models)
- Reverse pulse configuration
- Taps for gauges and mounting brackets

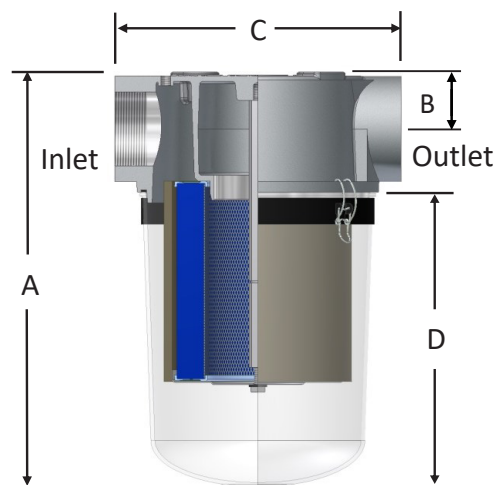

Inlet/Outlet Size	Type	Assembly m <sup>3</sup> /hr Rating	Assembly Part Number		Dimensions - mm				Suggested Service Ht. mm	Approx. Weight (kg)	Replacement Element Part No.		Element m <sup>3</sup> /hr Rating
			Polyester	Paper	A	B	C	D			Polyester	Paper	
1"	BSPP	68	ST-897-101C	ST-896-101C	340	303	178	264	228	5.0	897	896	136
1 ¼"	BSPP	102	ST-897-126C	ST-896-126C	340	303	178	264	228	4.7	897	896	136
1 ½"	BSPP	136	ST-897-151C	ST-896-151C	340	303	178	264	228	4.6	897	896	136
2"	BSPP	298	ST-851/1-201C	ST-850/1-201C	413	362	229	315	228	7.2	851/1	850/1	493
2 ½"	BSPP	357	ST-851/1-251C	ST-850/1-251C	413	362	229	315	228	6.8	851/1	850/1	493
3"	BSPP	510	ST-235P-301C	ST-234P-301C	502	432	343	356	228	13	235P	234P	968
4"	BSPP	884	ST-235P-401C	ST-234P-401C	502	432	343	356	228	11	235P	234P	968

\*See Vacuum Filter Technical Data for sizing guidelines and service data.

Rev: ST-EU1908K

# “T” Style Vacuum Filters

## CT Series 1” – 6”

### Features

- Compact design for space restrictions; min. service area
- Inlet above element for extended element life & maintenance intervals
- Corrosive resistant cast aluminum top with machined connections and integrated baffle design
- “T” style design minimizes piping requirements
- Black powder coat carbon steel drop down bucket



### Technical Specifications

- Vacuum Rating: medium vacuum service\*
- Temp (continuous): min -26°C (-15°F) max 104°C (220°F)
- Filter change out differential: 37-50 mbar over initial ΔP
- Polyester: 99%+ removal efficiency standard to 5 micron
- Paper: 99%+ removal efficiency standard to 2 micron

### Options



- Swing bolts for heavy duty environments
- Drain ports
- Extended bucket (select models)
- Various nonstandard finishes
- Reverse pulse configuration
- See-through bucket (select models)
- Taps for gauges and mounting brackets

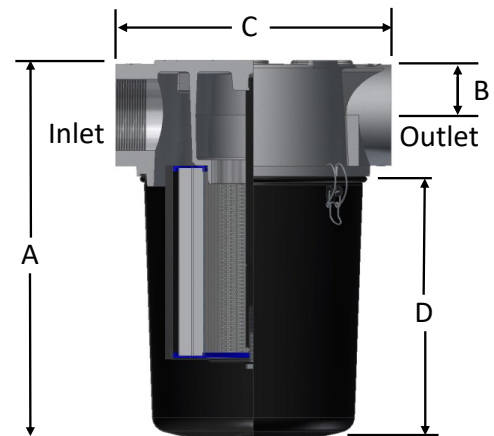

Inlet/Outlet Size	Assembly Type	Assembly m <sup>3</sup> /hr Rating	Assembly Part Number		Dimensions - mm				Suggested Service ht. mm	Approx. Weight (kg)	Replacement Element Part No.		Element m <sup>3</sup> /hr Rating
			Polyester	Paper	A	B	C	D			Polyester	Paper	
1"	BSPP	68	CT-897-101C	CT-896-101C	334	297	178	257	228	5.4	897	896	136
1 ¼"	BSPP	102	CT-897-126C	CT-896-126C	334	297	178	257	228	5.2	897	896	136
1 ½"	BSPP	136	CT-897-151C	CT-896-151C	334	297	178	257	228	5.1	897	896	136
2"	BSPP	298	CT-851-201C	CT-850-201C	325	275	229	229	228	7.2	851	850	493
2 ½"	BSPP	357	CT-851-251C	CT-850-251C	325	275	229	229	228	6.8	851	850	493
3"	BSPP	510	CT-235P-301C	CT-234P-301C	473	404	343	328	228	14	235P	234P	968
4"	BSPP	884	CT-235P-401C	CT-234P-401C	473	404	343	328	228	12	235P	234P	968
6"	BSPP	1870	CT-275P-601C	CT-274P-601C	483	363	483	249	254	20	275P	274P	1869

Note: CT 2" & 2 ½" models: Element seals on the base of the housing.

\*See Vacuum Filter Technical Data for sizing guidelines and service data.

Rev: CT-EU1908K

# Technical Data

## Inlet Vacuum Filters

### Applications & Equipment

- Industrial & Severe Duty
- Vacuum Pumps & Systems: Roots, Rotary Vane, Screw, Piston
- Vacuum Packaging Equipment
- Vacuum Furnace
- Blowers: Side Channel & P.D.
- Vacuum Lifters
- Intake Suction Filters
- Food Industry
- Woodworking/Routers
- Ash Handling
- Printing Industry
- Medical/Hospital
- Remote Installations for Piston & Screw Compressors
- Paper Processing
- Waste Water Aeration
- Cement Processing
- Bag House Systems
- Vacuum Vent Breathers
- Chemical Processing
- Factory Automation Equipment
- Leak Detection Systems

### Identification

Standard Solberg assemblies should have an identification label/nameplate that gives the following information:

- Assembly Model #
- Replacement Element #

The part number designates the filter type, the element configuration and housing connection size. For example, the following part number identifies the filter as being a “CSL” design filter with a “235” element, “P” prefilter and DN100 flange connection size.

#### CSL-235P-DN100

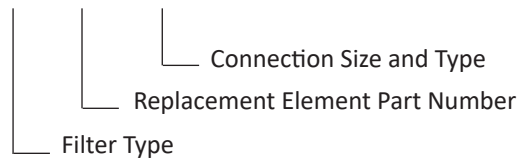

### Vacuum Service Rating Chart

Threaded vacuum filter connections must be free of defect and properly sealed to achieve deeper vacuum levels. Vacuum service levels are given for reference only and serve as a guideline for product selection. Product certification and alternative designs are available for applications requiring deeper vacuum levels and specific leak rates. Please contact factory for details.

Vacuum Level	Pressure (mbar)	Pressure (Torr)	Pressure (Pa)
Atmospheric Pressure	1013	760	1.013x10 <sup>5</sup>
Coarse Vacuum	1013 to 33	760 to 25	1x10 <sup>5</sup> to 3x10 <sup>3</sup>
Medium Vacuum	33 to 1.3x10 <sup>-3</sup>	25 to 1x10 <sup>-3</sup>	3x10 <sup>3</sup> to 1x10 <sup>-1</sup>
High Vacuum	1.3x10 <sup>-3</sup> to 1.3x10 <sup>-9</sup>	1x10 <sup>-3</sup> to 1x10 <sup>-9</sup>	1x10 <sup>-1</sup> to 1x10 <sup>-7</sup>

Rev: InletVacTech-EU0719K

# Inlet Vacuum Filters

## Choosing the Best Filter for Your Equipment

A. When the connection & airflow is known:

1. select the appropriate connection style. (i.e.: BSPT, Flange, BSPP, etc.)
2. check assembly m<sup>3</sup>/hr (flow) rating. Compare with your required airflow.

(Note: Assembly flow ratings are based on 6,000 FPM or 30m/sec for a given connection size to achieve low pressure drop performance. When required flow exceeds assembly flow rating, the pressure drop through the outlet connection will increase. In such cases select by element m<sup>3</sup>/hr (flow) rating.)

3. when required flow rating matches connection size; skip to "C. Selecting Elements".

B. When the connection size is unknown, flexible, or the required flow rating exceeds assembly flow rating:

1. match required flow rating with the element flow rating.
2. choose related connection size.

C. Selecting Elements: The filter performance is influenced by the actual application duty and the equipment it is installed on. Regular maintenance checks and proper servicing is required.

### **Application Duty Descriptions:**

Industrial Duty: clean workshop or clean outdoor environment - small element sizing is sufficient.

Severe Duty: dirty workshop, wastewater – medium to large element is recommended.

Extreme Duty: cement, steel making, plastics or dusty material conveying – largest element sizing is recommended.

1. Select media required by your application. Options include:

a. Standard media

1. Polyester: all purpose; withstands pulses, moisture, and oily air
2. Paper: mostly dry, smooth flow applications

b. Special Media: for a variety of micron levels and media types, see the "Filter Media Specifications" in the Replacement Element Section or contact Solberg.

2. Select element size by matching the element with the anticipated duty and upsize accordingly.

## Filter Assembly Maintenance

Request the appropriate maintenance manual for more in-depth information from your Solberg representative or on our website: [www.solbergmfg.com](http://www.solbergmfg.com).

## Element Maintenance

Solberg elements should be replaced once the pressure drop reaches 37-50 mbar above the initial pressure drop of the installation. Cleaning the element is also an option.

Solberg recommends replacing dirty elements for optimal performance. Any damage which results from by-pass or additional pressure drop created by element cleaning is the sole responsibility of the operator.

Note: The overall performance of a filter element is altered once cleaned. The initial pressure drop after subsequent cleanings will be greater than the original, clean pressure drop of the element. After each cleaning, the pressure drop will continue to increase. Under all circumstances, the initial pressure drop of the element needs to be maintained at less than 37 mbar.

If the pressure drop exceeds 50 mbar at start-up; it should be replaced with a new element. With many types of equipment, the maximum pressure drop allowed will be dictated by the ability of the equipment to perform to its rated capacity. Under all circumstances, the operator should avoid exceeding the manufacturer's recommended maximum pressure drop for their specific equipment.



All model offerings and design parameters are subject to change without prior notice.  
Contact your representative or Solberg for the most current information.

[www.nsltechnology.com](http://www.nsltechnology.com)

**NSL** NSL Technology Resources (s) Pte Ltd  
No 280 Woodlands Industrial Park E5,  
#09-11 Harvest @ Woodlands,  
Singapore 757322  
Tel : +65 67957477, 7747 Fax : +65 63162368  
Email : [sales@nsltechnology.com](mailto:sales@nsltechnology.com)